

**CXAR/64 & 128-CP MAINFRAME CHASSIS
with IF-12 Control Module**

This information is proprietary to CYTEC Corp., and is not to be used, caused to be used, reproduced, published or otherwise used/or disclosed in any way that might be detrimental or compromising to CYTEC Corp.

Table of Contents

1.0	ADDENDUM	6
2.0	GETTING STARTED	7
3.0	GENERAL	8
3.1	CHASSIS DESCRIPTION	8
3.1.1	MAINFRAME CHASSIS	8
3.1.2	EXPANSION CHASSIS	8
3.2	SPECIFICATIONS	9
3.3	POWER SUPPLY	9
3.4	FRONT PANEL	9
3.4.1	LABELING AND PROGRAMMATIC REFERENCES	10
3.4.2	CP8 LATCHING/DISPLAY MODULE	10
3.4.3	PUSHWHEEL MANUAL CONTROL OPTION	11
3.5	REAR PANEL	12
4.0	SWITCH MODULES	13
5.0	IF-12 GPIB / RS232 / LAN CONTROL MODULE	14
5.1	LAN INTERFACE	14
5.2	RS232 INTERFACE	15
5.3	IEEE488 INTERFACE	17
5.3.1	IEEE488.2 SPECIFIC MATRIX COMMANDS	18
5.4	CONFIGURING TCP/IP PARAMETERS FROM A SERIAL CONNECTION	18
5.5	RUNNING THE CYTEC FACTORY APPLICATION ON THE IF-12	20
5.6	COMMAND FORMAT/COMPLETION	21
5.6.1	END OF LINE CHARACTER (EOL)	21
5.7	SETUP COMMANDS	22
5.8	SWITCH COMMANDS	23
5.9	STATUS AND INTERROGATE COMMANDS	25
5.10	I – INTERROGATE COMMAND	26
5.11	OTHER COMMANDS	27
5.12	INPUT / OUTPUT vs MODULE / SWITCH NOMENCLATURE	28
5.13	LIST MANAGEMENT	29
5.14	MATRIX COMMAND SUMMARY	29
5.15	IF-12 (RS232/LAN/GPIB) DEFAULT CONFIGURATION SETTINGS	30
5.16	LCD DISPLAY/KEYPAD MANUAL CONTROL OPTION	31
5.17	MEMORY SANITATION PROCEDURE	32
APPENDIX	- EXAMPLE PROGRAMS	33
Java LAN Programming Example:	33
C LAN Programming Example	35
LabWindows RS232 Programming Example	39
LabWindows GPIB Programming Example	44
LabView Drivers	52

DRAWINGS

(Shipped configuration included. Other schematics available on request)

DRWG #	DESCRIPTION
11-21-50	IF-12 LAN/RS232/GPIB Control Module Schematic
12-00-50	CL64,128,256 Motherboard Schematic
12-01-50	CP64,128,256 Motherboard Schematic
12-02-50	CP Mainframe Adapter Card Schematic
12-04-50	68 PIN CP Adapter Card Schematic
16-07-51	MESA II EIF Module for CP128 Control
16-08-50	68-Pin Interface Transition Mod
16-15-50	68 Pin to Quad 16 Pin Adapter Mod
16-15-51	68 Pin to Quad 16 Pin Mod
21-32-00	Standalone 128 Channel Mainframe Chassis
21-32-21	CXAR/128 MF Rear Panel
21-33-00	Standalone 64 Channel Mainframe Chassis
21-33-21	CXAR/64-CP-MF Rear Panel
90-81-50	Pushwheel Front Panel
99-00-30	20 Pin Drive Cable
99-02-30	16 Pin Data Cable Diagram
99-190-30	Standard Power Supply Wiring Diagram
99-34-30	Mesa EIF Ribbon Cable Assembly

1.0 ADDENDUM

This page is intentionally left blank

2.0 GETTING STARTED

Unpack the unit and make sure it has arrived undamaged. Inspect for dents, bent handles, major scratches and missing or loose parts. Note that many of the items listed individually on the packing list are already installed within the chassis, rather than being packed separately.

Compare the Shipped Configuration List on the last page of the Quick Start Guide that shipped with the unit with the included packing slip to verify that all components and ordered parts have been received. If any purchased items are missing please contact your Sales Representative at 1-800-346-3117, 585-381-4740 or sales@cytec-ate.com. Utilize the Shipped Configuration List to identify which drawings and diagrams refer to the specific unit ordered.

Next, set up the chassis on either a bench or rack. The front handles allow the unit to be bolted to a standard 19 inch rack. No special setup tools are needed.

For AC powered units, a Power Cord should be included in the box. Plug one end into the chassis and the other into a three prong commercial AC outlet. The unit will operate from one of two AC voltage ranges: 100/140 or 200/260. There is a fuse holder built into the front panel of the unit. The power supply on AC units is auto-ranging.

Install the appropriate remote control cable to the controlling computer: RS232, IEEE488 (GPIB) or Ethernet. Cytec provides a one to one RS232 D9 cable but does not provide Ethernet or GPIB cables with the unit.

Turn the unit ON via the toggle switch located on the front panel. The front panel Power LED should illuminate.

Study the sections of this manual which deal with your control interface (RS232 or Ethernet), as well as the controlling command syntax. A group of programming examples are included in appendices at the end of the manual and provide a good structure to work from. Example driver programs may be included on a disc if requested. Drivers can also be downloaded from Cytec's web site at: <http://www.cytec-ate.com/support>

You should now be able to begin writing useful code. **Always write and debug code thoroughly before hooking up live signals to the matrix!** This equipment gives you full control over what is switched to where and will not prevent you from making potentially harmful connections. That is, nothing in the system prevents the switching of excessive power, which can damage or destroy the relay contacts or digital switches.

3.0 GENERAL

The CXAR Series are Computer Controlled Coaxial Switching Systems designed for use with 50 or 75 ohm impedance signals. These systems are able to switch signals ranging from DC to 1.6 GHz, depending on the type of switch modules installed in the chassis (See Section 4.0).

3.1 CHASSIS DESCRIPTION

The CXAR/64-CP and CXAR/128-CP include both mainframe and expansion chassis. A mainframe is a single stand alone chassis which may be controlled either remotely via computer or locally via the optional Pushwheel Manual Control (See Section 3.4.3) or LCD with Keypad Manual Control (See Section 5.16). One or more expansion chassis can be controlled only from a dedicated MESA control chassis.

Refer to the "Shipped Configuration" sheet included with the system to determine which of the chassis assembly drawings pertain to the system purchased. These assembly drawings will show the placement and locations of the various modules.

3.1.1 MAINFRAME CHASSIS

A typical CXAR/64-CP Mainframe is shown on **Drwg. #21-33-00**, and a CXAR/128-CP Mainframe can be seen in **Drwg. #21-32-00**. The Mainframe is a 19" rack mounting chassis, approximately 15" deep. Chassis height is determined by switch module selection and configuration but is typically either 5.25" or 7.0".

The CXAR Mainframe chassis contains:

- (1) CP/64 or CP/128 Motherboard (Section 3.4.2)
- (up to 16) CP8 Display/Driver modules (Section 3.4.2)
- (up to) 16 coaxial switch modules (Section 4.0)
- (1) Control Module (Section 5.0)
- (1) +12 Vdc Power Supply (Section 3.3)
- (1) +5 Vdc Power Supply (Section 3.3)

3.1.2 EXPANSION CHASSIS

An expansion chassis differs from the mainframe in that it can not operate as a stand alone device and must be controlled remotely from a Cytec supplied MESA control chassis. Similar to the mainframe, the expansion chassis is also a 19" rack mounting chassis, approximately 15" deep and either 5.25" or 7" high.

The CXAR/64 and CXAR/128 Expansion Chassis contains the same components as the CXAR Mainframes with the following exception:

The control module is replaced by the Expansion Interface Module **Drwg. #12-04-50**.

For Expansion Chassis, control signals originate in the MESA Control Mainframe. These

signals are routed from the MESA via the supplied Ribbon Expansion Cable to the Interface Connector located on the chassis' rear panel. The Interface Connector in turn wires to Expansion Interface Module located inside the chassis. The Expansion Interface Module plugs into the Control Motherboard, serving the same function as a Control Module (**See Section 5.0**).

3.2 SPECIFICATIONS

Dimensions:	19" rack mounting x 5.25", 7", or 8.75" high x 15.6" deep
Weight:	Maximum weight with full complement of modules less than 30 lbs.
Power:	Less than 100 W @ 100-130 Vac or @ 200-260 Vac
Environment:	
Operating:	0 C to 50 C @ 95% Relative Humidity
Storage:	-25 C to 65 C @ 95% Relative Humidity
Capacity:	Standard up to 16 switch modules
Expansion Capacity:	Up to 16 expansion chassis with one MESA Control Chassis
Display:	One power LED and up to 128 drive status LED's
Control Mode:	IEEE488, RS232, and Ethernet TCP/IP standard. USB and manual control optionally available.

3.3 POWER SUPPLY

The CXAR/64-CP and CXAR/128-CP Mainframe Chassis hold two power supplies, one with a regulated +12 Vdc output for driving the relays and one with a regulated +5Vdc output for the logic as shown in **Drwg. 99-190-30**.

The supplies are wired to the Selectable AC Input Module on the rear panel, which also holds the chassis' ON/OFF Switch. The user can select one of two AC voltage ranges: 110/120 Volts or 220/240 volts AC. The power supplies will operate from 100-140 volts or 200-260 volts at 47-63 Hz. To change the selected voltage, remove the fuse cartridge using a small blade screw driver or a similar tool. Select the desired voltage by matching the arrow on the fuse cartridge to the arrow located on the Input Module's lower right corner. *Replace the fuse cartridge making sure the voltage selection arrow aligns with the arrow located on the Input Module.*

Two fuses are held in the fuse cartridge, with 220/240 VAC fused separately from 110/120 VAC. See the "Shipped Configuration" section for fuse sizes.

3.4 FRONT PANEL

The front panels of the CXAR/64 and CXAR/128 include one power LED, up to 128 display LED's (8 LED's per CP8) and an optional pushwheel or LCD manual control.

3.4.1 LABELING AND PROGRAMMATIC REFERENCES

The front panel of the CXAR/64-CP or CXAR/128-CP chassis is typically labeled to match the chassis' built-in switching configuration. Each switch point is assigned a single front panel status LED. Each column of LED's represents a logical switch module, and each LED in that column represents a single specific switch within that module. The LED's are visible through the panel.

Programmatically, any command references one switch point and its corresponding LED directly. Commands are of the form: *Command Module, Switch*, where:

- Command* - One letter mnemonic indicating function to be performed (L for Latch, U for Unlatch, etc.)
- Module* - An integer specifying the logical module being address. Matches front panel configuration. (0 - 15 for a 16x8 Matrix, 0 - 31 for a 32x4 matrix, etc.)
- Switch* - An integer that specifies logical switch being addressed. Also matches front panel labeling and chassis configuration. (0 - 7 for 16x8 matrix, 0 - 3 for 32x4 matrix, etc.)

Examples:

- 16(8x1) Independent Multiplexers** - "L 0 7"- Latches Module 0, Switch 7
"U 15 0" - Unlatches Module 15, Switch 0

See Section 5.0 for complete programming information.

Note that the Latch command causes the assigned front panel LED to illuminate, indicating that the switch has been closed. Similarly, the Unlatch command will extinguish a LED if it is already illuminated (indicating a closed switch has been opened).

3.4.2 CP8 LATCHING/DISPLAY MODULE

The CP8 Module (**Drwg. #13-08-50**) interfaces between the control bus on the CP Motherboard and the switch modules. The CP8 includes the logic to select and Latch (close) up to eight relays in Matrix mode. The output driver has diode suppression and energizes the relay coil via an LED in parallel with the coil to give a positive indication that the relay is energized.

Additional logic checks whether the relay is energized and returns its Status to the computer.

Matrix/Multiplex Modes

There are two basic modes of operating the modules, either as a Matrix where any number of switches can be latched, or as a Multiplexer where one and only one switch is latched.

Status Mode

A switch point is addressed for Status return the same way as it is addressed for any other operation (for example, a Latch). If the switch is energized, a Status of "1" is returned. If de-energized, a "0" is returned.

CP/64, 128 MOTHERBOARD

As shown in **Drwg. #12-01-50**, this motherboard has up to 16 slots for the CP8 Latching/Display Modules and one slot for the Control Module Adapter Module (See **Drwg. #12-02-50**).

Power, consisting of regulated +12 Vdc for the relays, +5 Vdc regulated for the logic and ground, is bussed to all the module slots. Also bussed to all the CP8 Module slots are the mode controls, which include Latch/Unlatch, Matrix/Multiplex, Switch Strobe, Status Strobe and Status return.

3.4.3 PUSHWHEEL MANUAL CONTROL OPTION

Note: This section covers the optional Pushwheel Manual Controls. For information on the alternative Keypad with LCD Manual Controls, see Section 5.16, below.

The Optional Pushwheel Manual Controls are located on the front panel and are wired as shown on **Drwg. 90-81-50**. The controls wire out via a 16 pin DIP connector which mates with the socket located on the control module.

Local/Remote

There are two front panel LEDs: a green LED labeled Remote and a red LED marked Local. When the Local LED is lit, the unit can be operated from the manual controls. When the Remote LED is lit, the unit can only be operated via computer control. See also the 'F' command in Section 5.0 for information on changing between Local and Remote.

Switch Select

This consists of pushwheel switches. The left hand 1 or 2 pushwheels select the module and the right hand pushwheel selects the switch on that module. For example, with two pushwheels installed a setting of 23 selects Switch #3 on Module #2, however, the switch is not energized until after the selection has been Strobed via the front panel pushbutton.

Latch/Unlatch

With this control in the Latch position, the switch selected is latched (closed). In the Unlatch position, the switch selected is unlatched (opened). Switching this control from Latch to Unlatch does not disturb the status of the matrix, until the Strobe button is pushed.

Mtx/Mux

With this switch in the MTX position, any number of switch points can be latched at the same time. In the MUX position, only one switch point can be latched at any time. Switching between these two positions does not change the status of the matrix. For example, if the matrix was in the MTX mode and eight switches were closed, then after switching from MTX to MUX, the eight switches will remain closed until the Strobe pushbutton is pushed. This will then clear all switches except the one currently selected by the pushwheels.

Strobe

This is a pushbutton which sends the necessary strobe pulse to the matrix to complete the switch and mode selection indicated by the manual controls.

Clear

There is no single front panel button for clearing the matrix by opening all the switches. Clearing is achieved by putting the MTX/MUX switch in the MUX position, the Latch/Unlatch switch in the Unlatch position and then pressing the Strobe pushbutton. This sequence of required operations prevents the unit from being cleared accidentally.

3.5 REAR PANEL

The rear panels of the CXAR/64-MF Mainframe and CXAR/128-MF Mainframe are shown in Drawings **21-33-21** and **21-32-21** respectively. Drawings for the CXAR/64-E-PS Expansion Chassis and CXAR/128-E-PS Expansion chassis would be identical except the LAN, RS232 and GPIB control connectors would be replaced with a 68 pin header which attaches to the Mesa II Control Ribbon Cable provided with those chassis.

These drawings show the most common configuration of switch modules which may or may not be what you ordered. Since there are a lot of different CXR switch modules you may need a more specific drawing which Cytec is happy to provide upon request.

Modules for the CXAR/64 are typically installed vertically and are numbered 0 through 8 from right to left looking at the chassis from the rear. Switch Modules for the CXAR/128 are typically installed vertically and are numbered 0 through 15 from right to left looking at the chassis from the rear. The right to left numbering is so the modules line up with the CP8 Display / Driver modules in the front of the chassis. The associate Module numbers are shown across the top of the chassis and match the programmatic module address used to control the relays.

Switch / Relay numbers are shown to the right or left of the switch modules and are in a column like the front panel LED indicators. For 1xN modules the 1 connector is designated as COM (common) and the switch/relay numbers are arranged according to the programmatic address in relation to the specific connector.

4.0 SWITCH MODULES

Cytec currently offers over 50 different coaxial switch modules for installation in the CXAR/64 and CXAR/128-CP chassis. Both 50 and 75 ohm impedance modules are offered. Connector options include SMAs (50 ohms only), BNCs, Twin BNCs, or Type F (75 ohms only). Frequencies from DC to over 1.6 GHz can be handled. However, not all connector types and higher bandwidths are offered on all modules. A selection of switch modules can be viewed at the following link to Cytec's website:

<https://cytec-ate.com/application-guide/rf-type-selector/rf-modules/>

Note that the 'CXAR Coax Mux Systems' item should be checked under the 'Filters' heading to Display the switch modules for this system. Both Schematics and Data Sheets can be accessed By clicking on the link located on the same line as the switch module Name.

5.0 IF-12 GPIB / RS232 / LAN CONTROL MODULE

Introduction

CYTEC's IF-12 RS232/LAN Control Module is designed to control single chassis mainframes. Three forms of remote control are available on the module: IEEE488 (GPIB), RS232 and Ethernet LAN. An optional manual control is also available. All four interfaces may be active and used simultaneously.

Interface options: GPIB, RS232 and LAN are standard, but the manual control must be specified when purchasing the system. On some systems where panel space is limited, only two of the three interface connectors may be included.

5.1 LAN INTERFACE

Dynamic IP Address (DHCP): The Cytec IF12 is set at the factory to attempt to obtain an address from a DHCP server when the application boots. If you are connected to a network with a DHCP server, then the device IP address, network mask and gateway should be configured automatically. If your PC is on the same DHCP network, you will be able to communicate with the device after a short boot period of less than 10 seconds.

Static IP Address: If the module is plugged in to a network that does not have a DHCP server, you must provide a static IP address, network mask and gateway. These addresses should be provided by your network administrator.

Auto IP Address: The factory application contains an auto IP negotiation system. This allows the device to automatically configure its address in the absence of a central DHCP server, and without the need for a static IP address. This scheme is utilized as a fallback that will activate when both dynamic and static IP addresses fail to initialize. In order to communicate with a device in auto IP mode, the host system must support auto IP. Auto IP support is included in both Windows and OS X operating systems. By default, auto IP addressing starts in the 169.XXX.XXX.XXX address range.

Find Your Device: Our recommended option to locate the device is to use a local discover utility. You can do this by navigating to the Cytec web site and downloading the tool `localdiscover.exe` from <https://cytec-ate.com/discover-cytec-local>. The executable sends out a request to all Cytec devices on the local network. It opens a browser page on the first device to respond that lists all of the discovered devices, or a page that show that no devices were found.

Note: If these options are failing, there may be a firewall issue blocking the applications from sending the UDP broadcast that is used to locate Cytec devices. Always grant Cytec applications the ability to get through your OS firewall and ensure that UDP port 20034 is open for use.

5.2 RS232 INTERFACE

Signal Connections

The control module is pre-configured at the factory to operate as Data Communications Equipment (DCE) per the EIA RS232D Standard. In this configuration, the module transmits on the RxD Pin and receives on the TxD Pin. RTS is required to be high for the control module to transmit and CTS is output high by the control module to indicate a ready for data state and low when busy. The RS232 rear panel connector is a D9P (male) and can be run directly from a D9 computer COM port with a straight through (one to one) D9S to D9S cable. A null modem cable will not work with the factory default settings! Adaptors are available at any computer store to convert from D25 to D9. Do not use any adaptor that also acts as a null modem converter. If you are building your own cables, consult CYTEC Corp., for D25 to D9 pin out conversion.

D9P (male) PIN OUTS

Pin	Signal	Function
1	DCD	Not Used.
2	RxD	Data out of Control Module.
3	TxD	Data in to Control Module.
4	DTR	Not Used
5	Common	Signal Ground.
6	DSR	Not Used
7	RTS	Control Module requires + V to transmit.
8	CTS	Control Module provides +V when ready
9	RI	Not Used

Find Your Device

Open Device Manager on Windows computers and navigate to Ports. The COM port number will be bracketed next to the device description.

Configure Your Device

The RS232 interface can be accessed using any standard terminal emulation program such as PuTTY which can be downloaded from putty.org. Enter the COM port number in the field for the Serial line to connect to. The default values set at the factory are:

- Speed(baud): 9600
- Data bits: 8
- Stop bits: 1
- Parity: None
- Flow control: RTS/CTS (Hardware)

The first thing you should do is turn on Echo. This will enable you to see what you are typing. Make sure you turn Echo back off when you are done with the terminal session. Echo being left

on will normally interfere with programs written specifically to control the switch.

Echo

Echos the characters back to your screen while you type them so you can see what you type.

Command: "E 0 73" Turns Echo Off
 "E 1 73" Turns Echo On

Answerback

Answerback allows the Control Module to return information to the COM port. Answerback should almost always be left on. If Answerback is enabled, the Answerback byte **must** be read back by the requesting device. Failure to do so could have unpredictable results.

Command: "A 0 73" Turns Answerback Off
 "A 1 73" Turns Answerback On

Verbose

Verbose causes the system to return more specific information when you request status or read answerback characters. It is sometimes helpful when troubleshooting but it slows the interface down a lot. While there may occasionally be a good reason to turn on Verbose during a puTTY or Hyperterm session, it is almost never used in a programmatic interface. All of the same information can be generated in code based on the non-verbose responses without slowing down the RS232 interface.

Command: "V 0 73" Turns Verbose Off
 "V 1 73" Turns Verbose On

Baud Rate

Baud rate is set at the factory at 9600 Baud. Change is under software control and the control module must be connected to a serial interface to effect the change.

Baud	Baud# n
2400	4
4800	5
9600	6
19200	7
38400	8
57600	9
115200	10
230400	11 (untested, you should consider LAN)
460800	12 (untested, you should consider LAN)

Command: "P19 n 73"
 "P19 7 73" sets baud rate to 19200.

If the Baud rate is inadvertently set to an unknown rate, the default value may be restored. See

the section on Setting Defaults for the procedure.

Obviously as soon as you reset the Cytex baud rate you will no longer be able to communicate with the switch until you reset the baud rate on your controlling computer or communication device.

CTS/RTS Handshake

The Clear to Send (CTS) and Request To Send (RTS) hardware handshaking functions may be modified by the 'P6' command.

Command: "P6 handshake 73"

handshake = 0	Handshaking off
handshake = 1	Handshaking on (default)

Example

"P6 0 73" Turn handshaking off.

5.3 IEEE488 INTERFACE

Also known as GPIB (General Purpose Interface Bus), IEEE-488 is the international standard for a parallel interface used for attaching sensors and programmable instruments to a computer. When connecting IEEE-488 cables, some rules apply. The total number of devices should be 15 or less. The total length of all cables should not exceed 2 meters multiplied by the number of connected devices, up to a maximum of 20 meters. And no more than three connectors should be stacked together.

Find Your Device

Our recommended option to locate the device is to use NI Measurement & Automation Explorer (NI MAX), which can be downloaded from their website. Search for instruments in the application and the Cytex device should be found at default GPIB address 7.

Configure Your Device

GPIB Address:

Command syntax: "P14 n 73".

For example, "P14 8 73" sets the GPIB address to 8.

5.3.1 IEEE488.2 SPECIFIC MATRIX COMMANDS

These commands are ignored by the RS232 interface.

***IDN? - Revision Number** (Same as Cytec "N" - Revision Command)

Syntax: "*IDN?"

The 'IDN?' command will cause the matrix to return its current revision number followed by an end of line.

Send:	"*idn?"	Request revision number.
Receive:	"Cytec VDX/32x32 11-01-13 1.0" eol	Text string indicating rev.

***RST - Reset** (same as C - Clear command)

The '*RST' command will clear (open all switches) in the matrix.

Send:	"*rst"	Reset.
Receive:	"0" eol	Returns '0'.

5.4 CONFIGURING TCP/IP PARAMETERS FROM A SERIAL CONNECTION

To change parameters you will need to access the serial interface using any standard terminal emulation program from the COM port on your computer. Once you have established a serial connection the following commands can be used for configuration:

D command returns a list of current settings:

```
A1, E1, V0  Answerback = ON, Echo = ON, Verbose = OFF
Baudnumber = 6, RS Handshaking = 1
IP Address = 10.0.0.144
Netmask = 255.255.255.0
Gateway = 0.0.0.0
Port0 = 8080, Port1 = 8081
TCP idle = 60
Telnetlock = 0, Telnet Echo = 0
Battery Ram = 0, Default List = 0
```

IFConfig command is used to set the static IP address. The syntax for this command is:

```
ifconfig aaa.aaa.aaa.aaa nnn.nnn.nnn.nnn
```

a = ip address in dotted decimal format n = subnet mask in dotted decimal format

Example: `ifconfig 10.0.0.100 255.0.0.0`

Typing `ifconfig` and hitting the enter key will return the current settings.

Since you may be connected via Telnet to do this, **the IP address will not actually change until you reboot the Cytec switch**. This helps prevent anyone from mistakenly setting the IP to an unknown address by accident. It is a good idea to double check the settings with the `D` command before you reboot.

HOSTS command sets the gateway for TCP/IP sockets. The syntax for this command is:

```
HOSTS xxx.xxx.xxx.xxx
```

Example: `hosts 10.0.0.100`

Typing `hosts` and hitting the enter key will return the current settings.

SNET TCP PORT command sets the Port number for TCP/IP sockets. The syntax for this command is:

`SNET TCP PORT n m` where `n` = equals one of two sockets and `m` is the port number

Example:

```
snet tcp port 0 8088 socket 0 is port #8088
snet tcp port 1 8089 socket 1 is port #8089
```

Port numbers must be between 1024 and 65535.

The Telnet port (23) may also be available. See `TELNETLOCK` command.

SNET TCP Idle command sets the socket life for the connection. The syntax for this command is:

```
SNET TCP Idle n (n=seconds) (1 to 3600 sec)
```

```
Default = 60 sec
```

```
SNET TCP Idle (display)
```

```
TCP Idle = 60
```

```
SNET TCP Idle 0 Socket never dies until the computer that established the socket kills it.
```

Setting the TCP Idle to 0 will force the socket to stay alive until the program that established the socket kills it.

WARNING: This can lead to issues if there is a network disconnect or the computer that

established the socket locks up. If the computer that establishes the socket cannot kill the socket, no one will be able to connect to the switch until the Cytec unit is rebooted.

TCPAnswerback – Answerback

Syntax: TCPANSWERBACK n n = 0, 1 or 2

Answerback will enable or disable the transmission of a single character followed by an end of line upon the completion of all commands. The Answerback character will be a 1 or 0 depending on what command is sent. It is used to verify that the command was accepted and can verify completion of relay control commands. See **Section 5.5.2**

Eg.	"TCPANSWERBACK 0 "	Turn answerback off.
	"TCPANSWERBACK 1 "	Turn answerback on
	"TCPANSWERBACK 2 "	Turn answerback plus terminator on

Note: TCPANSWERBACK 2:

This setting appends a set of square brackets to the answerback byte.

Eg.	Send: "L0 0"	Latch Module 0 Switch 0.
	Receive: "1[]"	End of line follows the terminator

5.5 RUNNING THE CYTEC FACTORY APPLICATION ON THE IF-12

The factory application that is included with the IF12 Control module includes:

- System Parameter Settings
- Matrix Parameter Settings
- Remote Switch Control
- List/Config Management
- File Management
- Custom Labeling

The URL request in the browser should look like the following:

http://<Device IP>

Where <Device IP> is replaced with the corresponding IP address. For more information on finding the IP address of your device, please see the [device discovery](#) section of this manual.

5.6 COMMAND FORMAT/COMPLETION

COMMAND FORMAT

All commands consist of at least one ASCII character indicating the command followed by optional values. After the command string is sent, an End of Line Character must be sent to affect the command.

If values are included with the command, the first value does not need to be separated from the command; all subsequent values MUST be separated by spaces or commas, eg. L1 2.

Multiple commands may also be sent on one line. Commands must be separated by a semi-colon character. Command line length is limited to 19 characters so avoid abusing this feature.

Examples:	"L2 7;C"	Connects Input 2 to Output 7 then clear
	"U4 7;L 1 2"	Unlatch Mod 4, Sw 7 then Latch Mod 1, Sw 2

COMMAND COMPLETION

A code representing the last requested switch point status (open or closed) and command completion will be stored by the matrix.

If the LAN or RS232 answerback function is enabled, a single character followed by end of line will be sent upon completion of all commands. Answerback may also include a termination character.

Note: Command Completion is NOT updated until the matrix finishes the requested operation.

Command Completion Codes – See Section 5.8 for error and completion codes

5.6.1 END OF LINE CHARACTER (EOL)

A received end of line character will cause the control module to execute the ASCII command string. The end of line character may be sent as a carriage return (CR) or New Line / Line Feed (NL/LF) for RS232 interfaces and a New Line / Line Feed (NL/LF) for IEEE488 interfaces or LAN interfaces. The IEEE488 also allows for the END control line being true with the last data character to initiate the command.

Valid end of Lines:

CR, LF or NL	LAN, RS232 or IEEE488
CR and END	IEEE488
LF/NL and END	IEEE488

Note that the terms New Line and Line Feed are often used to mean the same thing.

Both are expressed as \n in most programming languages and are shown on the ASCII table as “LF”.

LF = Line Feed / New Line represented as \n, on ASCII table it is Decimal 10, or Hex A (0xA).

CR = Carriage Return represented as \r, on ASCII table it is = Decimal 13 or Hex D (0xD).

When any data is returned from the switch, the data will also be followed by an End Of Line character (EOL).

Notes - All Interfaces: Upon requesting status output characters MUST be received by the requesting device. Failure to do this will prevent further use of the matrix.

Access Code

Some commands require an access code number to be included with the command. This code prevents inadvertent operation of system modifying commands. The access code is 73.

5.7 SETUP COMMANDS

Matrixsize command sets the matrix size. The syntax for this command is:

```
matrixsize mtx# #mods #rlys
```

mtx#: For mainframes this is 0, for Mesa expansion systems this is the matrix number for the expansion chassis.

#mods: The maximum number of modules for the chassis.

#rlys: The maximum number of relays per module.

Example: matrixsize 0 16 8 Sets the # of modules to 16 and the maximum number of relays per module to 8 for a mainframe chassis (mtx is 0).

Typing matrixsize and hitting the enter key will return the current settings and chassis type (for Mesa systems all of the expansion chassis settings will be returned as a list).

P Commands (Except for communications settings these are set at the factory to the correct value for your system and should not need to be altered)

- P0 n 73 Set maximum number of matrices to ‘n’. For Mainframes n = 1, for Mesa Control n = number of expansion chassis
- P6 n 73 n can be 1 or 0. 1 turns RTS/CTS handshaking on, 0 turns RTS/CTS handshaking off. This setting only applies to serial communication.

- P7 n 73 n can be 1 or 0. 1 turns Use RAM on, 0 turns Use RAM off.
- P8 n 73 n can be 0 to 6. Sets the default list (configuration) to load at power up if Use RAM is on.
- P10 n 73 Set maximum number of modules to 'n' for a Mainframe system. For Mesa Systems sets the maximum number of modules for Matrix 0;
- P11 n 73 Set maximum number of modules in Matrix 1 of a Mesa System to 'n'.
- P12 n 73 Set maximum number of modules in Matrix 2 of a Mesa System to 'n'.
- P13 n 73 Set maximum number of modules in Matrix 3 of a Mesa System to 'n'.
- P14 n 73 Set GPIB address to 'n'. n can be 0 to 31.
- P19 n 73 Set the baud number to 'n'. See RS232 configuration section for corresponding baud rate to baud number.
- P20 n 73 Set maximum number of relays to 'n' for a Mainframe system. For Mesa Systems sets the maximum number of relays for Matrix 0;
- P21 n 73 Set maximum number of relays in Matrix 1 of a Mesa System to 'n'.
- P22 n 73 Set maximum number of relays in Matrix 2 of a Mesa System to 'n'.
- P23 n 73 Set maximum number of relays in Matrix 3 of a Mesa System to 'n'.
- P90 n 73 Set the system ID number to 'n'. Used in large systems to differentiate between chassis.

5.8 SWITCH COMMANDS

General Notes

For LAN and RS232, after sending any command the Cytec control will return an integer Answerback character if Answerback (TCPAnswerback for LAN) is ON. Answerback/TCPAnswerback is turned on by default and is Cytec's preferred operation since it allows you to verify commands are accepted before continuing.

If the command was a switch operation command such as Latch (L) or Unlatch (U), the character will be a meaningful status response where 1 = switch latched and 0 = switch unlatched. This may be used to verify that the command was received correctly.

Any other commands sent will also generate an answerback character which may be either a 1 or 0 and either character will indicate the command was received but the value is meaningless so either is acceptable.

Answerback may be turned off when using LAN or RS232 although it is not recommended. Answerback can also include a termination character for the LAN or RS232 interface.

Error Characters

If a command is sent incorrectly, an error character will be generated and added to the answerback character. Since the answerback character may be a 1 or 0, there may be two values for error characters as described below.

Answerback returned:

Dec	Hex	
1	30	Latch completed without errors.
0	31	Unlatch completed without errors.
2 or 3	32 or 33	Unknown command, first character unrecognizable.
4 or 5	34 or 35	Incorrect entries, number or type of entries incorrect.
6 or 7	36 or 37	Entries out of limits, switch point out of usable range.
8 or 9	38 or 39	Invalid access code, number 73 not included when required.

Delays to Prevent Errors

It is important to recognize that with modern computers and control interfaces, it is possible to stream commands to the switch matrix faster than the relays can physically operate. Many electro-mechanical relays may take between 2 to 20 ms to close or open. This can result in unpredictable results if certain operations are streamed together without considering this delay.

A good example of this type of problem occurs if a Latch command is sent and is immediately followed by a status request. Many of Cytec's products actually base status on current flow through the relay drives so it is possible to send a command and request status before the relay has physically operated, resulting in incorrect status feedback.

Typically, a 5 to 20 ms delay between commands requiring feedback can ensure that this is never an issue.

L,U,X – Latch, Unlatch, Multiplex Commands

Syntax: Cmd Switch

Cmd Module, Switch

Cmd Matrix, Module, Switch

The specified switchpoint is operated on. Note: For mainframe systems the matrix number will be 0.

(Cmd = 'L', 'U' or 'X')

L = Latch = Turn switch ON Closes the specified point, all others unaffected.

U = Unlatch = Turn switch OFF Opens the specified point, all others are unaffected.
X = Multiplex = Clear + Latch Opens all points, then Latches the specified point.

E.g. "U0 2 3" Matrix 0, Module 2, Switch 3 is opened. (OFF)
"L0 1 3" Matrix 0, Module 1, Switch 3 is closed. (ON)
"L0 1" Module 0, Switch 1 is closed. (ON)
"L2 3 7" Matrix 2, Module 3, Switch 7 is closed. (ON)
"X0 3 0" Clear all switch points (turn them all OFF) then Latch Matrix 0, Module 3, Switch 0.

If a single integer value is sent, the control module assumes it is a switch value and defaults to the last module value sent. If two integers are sent, the control module assumes they are a module and switch value and defaults to the last matrix value sent.

E.g. "L3 2 3" Matrix 3, Module 2, Switch 3 is closed (ON). Then, "L1 4" Assumes Matrix 3. Matrix 3, Module 1, Switch 4 is closed (ON). Then, "L5" Assumes Matrix 3, Module 1. Matrix 3, Module 1, Switch 5 is closed (ON).

Some Cytec programming examples may refer to Mod #, Rly # (Relay #). The terms Switch (Sw) and Relay (Rly) mean the same thing. For Unidirectional matrix switches the Module # may be thought of as Input #, and the Switch or Relay # may be thought of as the Output #.

C - Clear Command

Syntax: C
All points in the chassis are opened.

E.g. "C" All switches in the chassis are opened.

For IEEE488.2, The C command is the same as the *RST (reset) function.

5.9 STATUS AND INTERROGATE COMMANDS

The Status and Interrogate commands return information to the user so they can determine what state each switch point is in before proceeding. The commands can be used to simply check the switch configuration, to verify connections, or to prevent unwanted connections.

The information returned by these commands can be different depending on what type of system you have. Please find the Status or Interrogate section for your specific system before writing code that is dependent on the returned values.

S - Status Command

Syntax: S Returns Status of entire mainframe chassis.
S0 Module# Returns Status of specified Module#.

S0 Module# Switch# Returns Status of specified Switch point.

Status may be requested of a single switch point or for the entire chassis. After receipt of the Status command the Matrix will return a character or string of characters representing the status, open or closed, of a switch point or switch points. A one, '1', signifies a closed switch point (ON) and a zero, '0', an open switch point (OFF).

In the case of a single switch point Status a single character is returned followed by an end of line.

For multiple switch points, a stream of 1's and 0's will be returned. How they are returned and what they mean is dependent on the type of system.

5.10 I – INTERROGATE COMMAND

Syntax: I

The Interrogate function will return a list of all closed (ON) switch points. Each switch point will be followed by an “end of line” (EOL). The switch point is listed as the Module# and then Switch#. For matrix applications such as a 16x16 this often translates into “Input # then Output #” or “Output # then Input #”. Since many systems are bi-directional Input vs Output may be dependent on how you are using it. For uni-directional systems, such as VDM, or DXM, the input vs output relationship will be carved in stone and you should be familiar with it.

	<I>	Request interrogation.	
	Receive:	<Module#><comma><space><Switch#><EOL>	
Eg.	Send	“I”	
	Receive	“0, 0” eol	Module 0, Switch 0 Closed. End of
line.		“1, 6” eol	Module 1, Switch 6 Closed. End of
line.		“3, 2” eol	Module 3, Switch 2 Closed. End of
line.		“0” eol	Answerback character (if enabled).
End of line.			

For system such as a DX/256x256 the “I” command may return up to 256 addresses. Be sure your buffer size can handle the amount of returned data.

For Unidirectional matrix switches, specifically DX, DXM, VDX, VDM and TX, the Module # may be thought of as Input #, and the Switch or Relay # may be thought of as the Output #.

5.11 OTHER COMMANDS

F - Front Panel

Syntax: F n 73 n = 0 or 1

Front panel lock-out will be initiated by the receipt of a 0 character and enabled by the receipt of a 1 character followed by the access code. The access code prevents inadvertent lock-out from occurring. Lock-out will prevent any operation of the system from the front panel until it is terminated from the remote (F 1) or power is turned off then on. Preset to panel enabled at power on.

Eg. "F 0,73" Lock-out local operation.
"F 1 73" Enable local operation.

P - Program

Syntax: P n1,n2,73

The program command allows the operator to setup matrix dependent variables. These include matrix switch configuration and certain interface functions. Use of the P commands is complicated and varies greatly between systems. Your system should have been provided with the correct P command set-up.

If you need to change the matrix configuration, number of allowed modules, or other obscure set-up configurations on your system we recommend you contact Cytec and we can walk you through the P commands needed for your specific system. Please provide the serial # of your system when you contact us.

N - Revision Number (Same as IEEE488 *IDN?)

Syntax: N

The 'N' command will cause the matrix to return its current revision number followed by an integer identifier, followed by an end of line.

Eg. Send: "N" Request revision Number
Receive: "Cytec 11-14-10-1, 1.23 0" eol Text string indicating revision.

Where: "Cytec" = manufacturer.

"11-21-10" = control module board number (example).

"2.21" = Firmware Revision # (example).

"0" = Integer identifier.

Note: When requesting the Revision number, all characters must be received before the system can be resumed.

**NOTE - The text string received from the N' Command will vary depending on the type of system.*

Integer identifier

The N command now includes a single byte which can be used as an identifier for Cytec systems. The identifier is a single byte integer so it may 0 to 255. WE do not assign this and it has no meaningful relationship to any product. It is simply a number which may be assigned to a chassis so that the end user can acknowledge that a specific Cytec chassis is communicating. It is up to the customer to assign the number and keep track of it. It allows them to poll multiple chassis and know that the one they are talking to is, for example, the JX/256 that they assigned the identifier "13" to.

Command to enter or change the number:

P90 n 73 where n is the number from 0 to 255

5.12 INPUT / OUTPUT vs MODULE / SWITCH NOMENCLATURE

Most of the switching systems sold by Cytec are completely bi-directional and can be used in a variety of ways by the customer so it is impossible for us to use the terms Input and Output, even though it is what probably makes the most sense to the end user when connecting signals to the switch.

We label and control the switches using Module# and Switch# to avoid this confusion since for most systems either can be considered an Input or an Output.

However some Cytec systems are uni-directional and therefore do have assigned Inputs and Outputs:

Uni-directional Systems with defined Input and Output ports:

DX and DXM high speed digital switch matrix systems
VDX and VDM analog or digital switch matrix systems
TX analog systems
FX fiber optic systems

For all of these systems:

Module # = Input
Switch # = Output

Note that these systems will all allow multiple Outputs to be connected to a single Input, but will never allow multiple Inputs to be connected to one Output. There are internal controls to prevent this and attempting to do it will simply disconnect a previously set path.

5.13 LIST MANAGEMENT

Lists can be set most easily through the device webpage, which can be accessed by typing the IP address for the system into any browser address bar. Currently, Cytec switches allow only nine saved lists and list 0 is always the current latched points. Valid values for n are 1-9.

- BS n 73: Saves the current latched switchpoints in List n
- BL n 73: Clears the switch and loads the switch points in List n.
- BD n 73: Displays the switch points in List n.
- BC n 73: Clears List n.

5.14 MATRIX COMMAND SUMMARY

COMMAND	FUNCTION
L sw L mod, sw	Latch switch point.
U sw U mod, sw	Unlatch switch point.
X sw X mod, sw	Multiplex switch point.
C	Clear entire system.
S S mod, sw	Return status.
I	Interrogate Closed Points.
F 0/1 73	Disable/Enable Front Panel.
P parameter value 73	Program parameter.
N	Revision Number

RS232 Specific Commands

R baud, RTS/CTS 73	Baud Rate, RTS/CTS operation.
A 0/1 73	Disable/Enable Answerback.
E 0/1 73	Disable/Enable Echo.

V 0/1 73

Disable/Enable Verbose.

TCP/IP Specific Commands

TCPANSWERBACK 0/1/2

Disable/Enable Answerback/Termination

IFCONFIG aaa.aaa.aaa.aaa nnn.nnn.nnn.nnn

a = ip address in dotted decimal format
n = subnet mask in dotted decimal format

SNET TCP PORT n m

Where n = equals one of two sockets and m is the port number

5.15 IF-12 (RS232/LAN/GPIB) DEFAULT CONFIGURATION SETTINGS

System parameters can be set most easily through the device webpage, which can be accessed by typing the IP address for the system into any browser address bar.

Default Values

TCP Settings:

Port 0	8080
Port 1	8081
Socket Timeout	60 seconds
TCPAnswerback	1 (on)
TelNet Lock	0 (off)

Serial Settings:

Answerback	1 (on)
Verbose	0 (off)
Echo	0 (off)
Baudrate	9600
RS Handshake	1 (RTS/CTS)

GPIB Settings:

GPIB Address	7
--------------	---

Front Panel Settings:

Mux Config	0 (Single 32) only for 16 or 32 channel systems
Front Panel	1 (on)

Miscellaneous Settings:

Use RAM (startup)	0 (off)
Default List	0 (currently latched switchpoints)
Sys ID Number	0

5.16 LCD DISPLAY/KEYPAD MANUAL CONTROL OPTION

The Keypad/Display option allows manual control of the matrix from the front panel. Keypad operation is always enabled at power on but may be disabled by the remote command, 'F 0 73'.

Display

The display contains two lines with sixteen characters per line. The top line displays matrix commands and numeric entry. The bottom line displays the status of the entry or operation. The display will also show the last command entered from the remote computer interface when the front panel is enabled.

Keypad

The keypad consists of ten numeric keys, four function keys, a space key and an enter key.

<u>Key</u>	<u>Function</u>
0-9	Numeric entries.
space	Delimits between numeric entries.
L	Latch operation.
U	Unlatch operation.
X	Multiplex operation.
C	Clear operation.
ENTR	Execute displayed operation.

Operation

A matrix command key, **L**, **U**, **X** or **C**, MUST be pressed before numeric entry keys. Pressing any key except a matrix command key causes the message **Enter Cmd First** to be displayed. After pressing a matrix command key the command and a cursor are displayed. The switch point to be operated on may now be entered with the numeric and space keys. The entry format is the same as described in the MATRIX OPERATION section and described briefly by the following table:

<u>Command Key</u>	<u>Display Line 1</u>	<u>Line 2</u>
L	Lat _	Enter Point
U	Unl _	Enter Point
X	Mux _	Enter Point
C	Clr _	Enter Matrix

The numeric keypad now allows selection of the Module and Relay (Input and Output) to be operated on. Each entry may be multiple digits and a space must be pressed between selections.

<u>Key</u>	<u>Line 1 Display</u>	<u>Line 2 Message</u>
L	Lat _	Enter Point
1	Lat 1_	
Space	Lat 1 _	
2	Lat 1 2_	
3	Lat 1 23_	
Enter Key	Lat 1 23_	1

The **ENTR** key may now be pressed to execute the displayed operation. If the displayed entry is

incorrect or the operation is not desired, pressing any matrix command key will clear the display and restart the entry.

Status Display

After the **ENTR** key is pressed, the displayed operation is attempted to be executed by the control module. If the execution is successful, a **Point Closed** or **Point Open** message will be displayed on line 2. If the operation cannot be executed, an error message will be displayed.

<u>Line 2 Message</u>	<u>Status</u>
Ready	Displayed after power on.
Enter Point	The ENTR key has not been pressed, command and selection mode.
Point Closed	The selected point was closed.
Point Open	The selected point was opened.
Points Open	All points opened, Clear operation.
***Err: limits	The selected point is outside the programmed size of the matrix.
***Err: entry	An incorrect entry was selected.

Front Panel Disable

The 'F' command allows enabling or disabling front panel operation. If the front panel is disabled, no operation can be performed from the keypad.

<u>Remote Command</u>	<u>Line 1</u>	<u>Line 2</u>
F 0 73	Panel	Disabled
F 1 73	Panel	Enabled

Contrast and LED Backlight Adjustment

Controls are provided to adjust the LCD contrast and LED backlight level. These controls should only need adjustment in extremely bright or dim environments or for acute viewing angles. Both LCD and LED circuits have temperature sensing elements that will automatically adjust the output level for changes in the ambient temperature.

5.17 MEMORY SANITATION PROCEDURE

Cytec's IF-12 uses the NXP MCF54415 microprocessor with 32 MB of non-volatile flash memory which is used to store user lists and labels for the webpage factory application and 128kB of user parameter storage. If the unit is ever removed from service or needs to be sanitized for disposal the memory can be erased using one of the following methods.

- 1) Easiest with least damage. Contact Cytec for factory application .bin file at: sales@cytec-ate.com or 1-585-381-4740.
- 2) Permanent. Remove cover. Locate IF-12. Remove the NetBurner core board by disconnecting the LAN cable and prying the module off the IF-12 board. Destroy the NetBurner board. Unit is non functional until IF-12 has been replaced.

APPENDIX - EXAMPLE PROGRAMS

Java LAN Programming Example:

```
import java.net.*; // for Socket
import java.io.*; // for IOException and Input/OutputStream

public class if12_lantester
{
    static final int N_MODS = 4;
    static final int N_RLYS = 12;

    /**-----test if12 utility functions-----*/

    public static void main(String[] args) throws IOException, InterruptedException
    {
        if (args.length != 2) // Test for correct # of args. IP Address and Port
            throw new IllegalArgumentException("Parameter(s): <IP Address> [<Port>]");

        String server = args[0]; // Server name or IP address
        int servPort = Integer.parseInt(args[1]); // Port Number

        // Create socket that is connected to server on specified port
        Socket socket = new Socket(server, servPort);
        System.out.println("Connected to server...sending string");
        InputStream in = socket.getInputStream();
        OutputStream out = socket.getOutputStream();

        if12_lan if12 = new if12_lan();

        // Initialize Device: Turn Verbose & Echo off, Answerback on
        if (if12.init_LAN(in,out) < 0)
            throw new SocketException("Error Initializing Device");

        // Clear Device: Unlatch all relays
        if (if12.matrix_clear(in,out) != 48)
            throw new SocketException("Error clearing Device");

        // Latch and Unlatch Relays
        for (int mod =0; mod < N_MODS; mod++)
        {
            for (int rly=0;rly<N_RLYS;rly++)
            {
                if (if12.point_ops(in,out,'L',0,mod,rly) != 49)
                {
                    System.out.printf("Error latching Mod %d Rly %d\n",mod,rly);
                    break;
                }
            }
        }
    }
}
```

```

        }
        System.out.printf("Latched Mod %d Rly %d\n",mod,rly);
        if (if12.point_ops(in,out,'U',0,mod,rly) != 48)
        {
            System.out.printf("Error unlatching Mod %d Rly %d\n",mod,rly);
            break;
        }
        System.out.printf("Unlatched Mod %d Rly %d\n",mod,rly);
    }
}

socket.close(); // Close the socket and its streams
}
}

public class if12_lan
{
    private int bytesRcvd,bytesSent;
    private byte[] rcvBuffer = new byte[256];

    public if12_lan()
    {
        bytesRcvd = 0;
        bytesSent = 0;
    }
    /**-----Initialize Device-----*/
    public int init_LAN(InputStream in, OutputStream out) throws IOException,
        InterruptedException
    {
        String str =new String("E0 73;V0 73;TCPANSWERBACK 1\n");
        // Convert string to bytes for writing to output stream
        byte[] byteBuffer = str.getBytes();
        // Send the encoded string to the if12
        out.write(byteBuffer);
        Thread.sleep(1000); //Wait one second
        // Receive the response from the device
        if ((bytesRcvd = in.read(rcvBuffer,0,9)) != 9)
            return -1;
        return 0;
    }
    /**-----clear matrix-----*/
    public int matrix_clear(InputStream in,OutputStream out) throws IOException
    {
        String str = new String("C\n");
        // Convert string to bytes for writing to output stream
        byte[] byteBuffer = str.getBytes();
        // Send the encoded string to the if12

```

```

    out.write(byteBuffer);
    // Receive the response from the device
    if ((bytesRcvd = in.read(rcvBuffer,0,3)) == -1)
        return -1;
    return rcvBuffer[0];
}
/**-----switchpoint operations-----*/
public int point_ops(InputStream in, OutputStream out,char cmd,int mtx,
    int mod,int rly) throws IOException, InterruptedException
{
    //Format command string to send to device
    String cmd_line = String.format("%c%d %d %d\n",cmd,mtx,mod,rly);
    // Convert string to bytes for writing to output stream
    byte[] byteBuffer = cmd_line.getBytes();
    // Send the encoded string to the if12
    out.write(byteBuffer);
    Thread.sleep(100); //Wait 1/10 second
    // Receive the response from the device
    if ((bytesRcvd = in.read(rcvBuffer,0,3)) == -1)
        return -1;
    return rcvBuffer[0];
}
}

```

C LAN Programming Example

```

/* Cytec Matrix Test Program for LAN */
/* This program uses Microsoft's WS2_32 Library */
/* and winsock2.h. These are available in the */
/* Microsoft SDKs and can be downloaded from */
/* Microsoft's Developer Network */
/* https://msdn.microsoft.com/en-us/default.aspx */

#include <stdio.h>
#include <winsock2.h>
#include <stdlib.h> /* for exit() */

int init_LAN(int sock);
int point_ops(int sock,int cmd, int mtx, int mod, int rly);
int matrix_clear(int sock);
void DieWithError(char *errorMessage);

#define MAX_MTX 1
#define MAX_MOD 4
#define MAX_RLY 12

```

```

int main(int argc, char *argv[])
{
    int sock;
    char *servIP = "10.0.0.144"; /*Default IP Address*/
    struct sockaddr_in servAddr; /* IP address */
    unsigned short servPort = 8080; /* Port */
    int mtx, mod, rly, status;

    if (argc == 3)
    {
        servIP = argv[1];
        servPort = atoi(argv[2]);
    }

    WSADATA wsaData; /* Structure for WinSock setup communication */
    WSASStartup(0x202, &wsaData); /* Load Winsock 2.2 DLL */

    /* Create a reliable, stream socket using TCP */
    if ((sock = socket(PF_INET, SOCK_STREAM, IPPROTO_TCP)) < 0)
        DieWithError("socket() failed");

    /* Construct the server address structure */
    memset(&servAddr, 0, sizeof(servAddr)); /* Zero out structure */
    servAddr.sin_family = AF_INET; /* Internet address family */
    servAddr.sin_addr.s_addr = inet_addr(servIP); /* Server IP address */
    servAddr.sin_port = htons(servPort); /* Server port */

    /* Establish the connection to the server */
    if (connect(sock, (struct sockaddr *) &servAddr, sizeof(servAddr)) < 0)
        DieWithError("connect() failed");

    /* Initialize Device using init_LAN Function */
    init_LAN(sock);

    /* Send Clear Command to Device with matrix_clear Function */
    if ((status = matrix_clear(sock)) != 48)
        printf("Error clearing device/n");

    /* Simple looping through switchpoints */

    for(mtx=0; mtx<MAX_MTX; mtx++)
    {
        for (mod=0; mod<MAX_MOD; mod++)
        {
            for (rly=0; rly<MAX_RLY; rly++)

```

```

    {
    if (((status = point_ops(sock,'L',mtx,mod,rly))) !=49)
        printf("Error point %d %d %d not closed\n",mtx,mod,rly);
        else
            printf("Latched point %d %d\n",mod, rly);

            if (((status = point_ops(sock,'U',mtx,mod,rly))) !=48)
                printf("Error point %d %d %d not open\n",mtx,mod,rly);
                else
                    printf("Unlatched point %d %d\n",mod, rly);
            }
        }
    }
    closesocket(sock);
    WSACleanup(); /* Cleanup Winsock */
    return 0;
}
/*-----Initialize-----*/

int init_LAN(int sock)
{
    char rcvString[40]; /* Buffer for device response */
    int rcvStringLen; /* Length of device response */
    void DieWithError(char *errorMessage);
    /* Initialize Device */
    if ((send(sock, "E0 73;V0 73;TCPANSWERBACK 1\n", 28, 0)) != 28)
    {
        DieWithError("send() failed");
    }
    Sleep(1000); /* Wait for Response from Device */
    if ((rcvStringLen = recv(sock, rcvString, 9, 0)) < 9)
    {
        DieWithError("recv() failed or connection closed prematurely");
    }
    rcvString[rcvStringLen] = '\0';
    return 0;
}

/*-----Clear Matrix-----*/

int matrix_clear(int sock)
{
    char rcvString[8]; /* Buffer for device response */
    int rcvStringLen; /* Length of device response */

    if ((send(sock,"C\n",2,0)) != 2)

```

```

        DieWithError("send() failed");

    Sleep(200); /* Wait for Response

    /* Receive Response from Device */
    if ((rcvStringLength = recv(sock, rcvString, 10, 0)) <= 0)
        DieWithError("recv() failed or connection closed prematurely");
    rcvString[rcvStringLength] = '\0';
    int status = rcvString[0] & 0x3f;

    return status;
}
/*-----Switchpoint Operation----- */

int point_ops(int sock,int cmd, int mtX, int mod, int rly)
{
    char cmd_str[40]; /* Formatted command string */
    char rcvString[8]; /* Buffer for device response */
    int rcvStringLength; /* Length of device response */

    /* Format String */
    sprintf(cmd_str,"%c%d %d %d\n",cmd,mtX,mod,rly);

    /* Send Command to Device */
    if ((send(sock,cmd_str,strlen(cmd_str),0)) != strlen(cmd_str))
        DieWithError("send() failed");

    Sleep(200); /* Wait for Response

    /* Receive Response from Device */
    if ((rcvStringLength = recv(sock, rcvString, 10, 0)) <= 0)
        DieWithError("recv() failed or connection closed prematurely");
    rcvString[rcvStringLength] = '\0';
    int status = rcvString[0] & 0x3f;

    return status;
}

/*-----Error Handling Function-----*/

void DieWithError(char *errorMessage)
{
    fprintf(stderr,"%s: %d\n", errorMessage, WSAGetLastError());
    getchar();
    exit(1);
}

```

LabWindows RS232 Programming Example

```
*== Cytec Main Frame Control Include File rs232.h
=====*/

int RS232port;

/*== GLOBAL FUNCTION DECLARATIONS
=====*/

int CYRS232Initialize (int com_port, int baud_rate);
int CyIf3_read (char *buf);
int CyIf3_write (char *buf);
int CyIf3_close (void);

/*===== END */

#include <ansi_c.h>
#include <utility.h>
/*=====*/
/* Cytec Main Frame RS232 LabWindows/CVI Driver Module */
/*=====*/

#include <rs232.h>
#include <formatio.h>
#include "CYRS232.h"

/*= STATIC VARIABLES
=====*/
/* port contains the number of the port opened for the instrument module. */
/* cmd is a buffer for RS-232 I/O strings. */
/* rscnt contains the number of bytes transferred during a read or write. */
/* CyIf3_err: the error variable for the instrument module */
/*=====*/
//static int port;
static char cmd[26];
static int rscnt;
static int CyIf12_err;

/*= UTILITY ROUTINES
=====*/
int CyIf12_invalid_short_range (short val, short min, short max, int err_code);
int CyIf12_invalid_integer_range (int val, int min, int max, int err_code);
int CyIf12_invalid_longint_range (long val, long min, long max, int err_code);
int CyIf12_invalid_real_range (double val, double min, double max, int err_code);
int CyIf12_read_data (char *buf, int cnt, int term);
```

```

int CyIf12_write_data (char *buf, int cnt);
int CyIf12_device_closed (void);
void CyIf12_setup_arrays (void);

int main()
{
    CYRS232Initialize(12,9600);

}

/*=====*/
/* This function opens a com port for the instrument module, queries for */
/* ID, and initializes the instrument to a known state. */
/*=====*/
int CYRS232Initialize(int com_port, int baud_rate)
{
    char s[40];

    if (CyIf12_invalid_integer_range (baud_rate, 110, 19200, -2) != 0)
        return -14;

    CyIf12_err = OpenComConfig (com_port, "", baud_rate, 0, 8, 1, 512, 512);
    if (CyIf12_err<0) {
        return CyIf12_err;
    }
    CyIf12_err = SetComTime (com_port, 1.0);
    if (CyIf12_err<0) {
        return CyIf12_err;
    }

    /*
    Set port to the number of the port just opened.
    */

    RS232port = com_port;

    /* Initialize communication, Answerback ON, Verbose, Echo OFF */
    Fmt (s, "A1,73;V0,73;E0,73\r");
    CyIf12_err = (ComWrt (RS232port, s, StringLength(s)));
    if (CyIf12_err<0) {
        return CyIf12_err;
    }
    Delay(.1);

    CyIf12_err = ComRdTerm(RS232port, s, 40, '\r');

```



```

        if (CyIf12_err<0) {
            return CyIf12_err;
        }
        Delay (1.0);

        FlushInQ (com_port);
        FlushOutQ (com_port);

    return CyIf12_err;
}

/*=====*/
int CyIf12_read (char *buf)
{
    return(CyIf12_read_data (buf, 40, '\r'));
}

int CyIf12_write (char *buf)
{
    return (CyIf12_write_data (buf, StringLength(buf)));
}

/*=====*/
/* This function closes the port for the instrument module and sets the */
/* port to zero. */
/*=====*/
int CyIf12_close (void)
{
    /* Check for device closed */

    if (CyIf12_device_closed())
        return CyIf12_err;

    /*
    Close the com port. If error, set CyIf3_err = rs232err+300.
    */

    CloseCom(RS232port);
    if (rs232err != 0) {
        CyIf12_err = rs232err+300;
        return CyIf12_err;
    }

    RS232port = 0;

```

```

    return CyIf12_err;
}

/* = UTILITY ROUTINES ===== */

/*===== */
/* Function: Invalid Short Range */
/* Purpose: This function checks a short to see if it lies between a */
/*          minimum and maximum value. If the value is out of range, set */
/*          the global error variable to the value err_code. If the */
/*          value is OK, error = 0. */
/*===== */
int CyIf12_invalid_short_range (short val, short min, short max, int err_code)
{
    if ((val < min) || (val > max)) {
        CyIf12_err = err_code;
        return -1;
    }
    return 0;
}
/*===== */
/* Function: Invalid Integer Range */
/* Purpose: This function checks an integer to see if it lies between a */
/*          minimum and maximum value. If the value is out of range, set */
/*          the global error variable to the value err_code. If the */
/*          value is OK, error = 0. */
/*===== */
int CyIf12_invalid_integer_range (int val, int min, int max, int err_code)
{
    if ((val < min) || (val > max)) {
        CyIf12_err = err_code;
        return -1;
    }
    return 0;
}
/*===== */
/* Function: Invalid Long Integer Range */
/* Purpose: This function checks a long integer to see if it lies between */
/*          a minimum and maximum value. If the value is out of range, */
/*          set the global error variable to the value err_code. If the */
/*          value is OK, error = 0. The return value is equal to the */
/*          global error value. */
/*===== */
int CyIf12_invalid_longint_range (long val, long min, long max, int err_code)
{
    if (val < min || val > max) {
        CyIf12_err = err_code;

```

```

    return -1;
}
return 0;
}
/*=====*/
/* Function: Invalid Real Range */
/* Purpose: This function checks a real number to see if it lies between */
/*          a minimum and maximum value. If the value is out of range, */
/*          set the global error variable to the value err_code. If the */
/*          value is OK, error = 0. */
/*=====*/
int CyIf12_invalid_real_range (double val, double min, double max, int err_code)
{
    if ((val < min) || (val > max)) {
        CyIf12_err = err_code;
        return -1;
    }
    return 0;
}
/*=====*/
/* Function: Device Closed */
/* Purpose: This function checks to see if the module has been */
/*          initialized. If the device has not been opened, a 1 is */
/*          returned, 0 otherwise. */
/*=====*/
int CyIf12_device_closed (void)
{
    if (RS232port == 0) {
        CyIf12_err = 232;
        return -1;
    }
    return 0;
}

/*=====*/
/* Function: Read Data */
/* Purpose: This function reads a buffer of data from the instrument. The */
/*          return value is equal to the global error variable. */
/*=====*/
int CyIf12_read_data (char *buf, int cnt, int term)
{
    rscnt = ComRdTerm(RS232port, buf, cnt, term);
    FlushInQ (RS232port);

    return rscnt;
}

```

```

/*=====*/
/* Function: Write Data */
/* Purpose: This function writes a buffer of data to the instrument. The */
/* return value is equal to the global error variable. */
/*=====*/
int CyIf12_write_data (char *buf, int cnt)
{
    rscnt = ComWrt (RS232port, buf, cnt);

    return rscnt;
}

/*=====*/
/* This function is called by the init routine to initialize global arrays */
/* This routine should be modified for each instrument to include */
/* instrument-dependent commmand arrays. */
/*=====*/
void CyIf12_setup_arrays (void)
{
}
/*= THE END
=====*/

```

LabWindows GPIB Programming Example

```

/*=====*/

/*= Cytec IF-11 IEEE488 Control Module Include File =====*/

/*== GLOBAL CONSTANT DECLARATIONS
=====*/

/* Replace 10 with the maximum number of devices of this type being used. */
#define IF12_MAX_INSTR 10

/*== GLOBAL FUNCTION DECLARATIONS
=====*/
int if12_init (int, int, int *);

/** INSERT INSTRUMENT-DEPENDENT FUNCTION DECLARATIONS HERE **/

int if12_operate(int, int, int, int, int *);
int if12_write (int, char *);
int if12_read (int, int, char *, int *);
int if12_close (int);

```

```

/*=== END INCLUDE FILE
=====*/

/*=====*/

#include <gpib.h>
#include <utility.h>
#include <formatio.h>
#include "cy_if12.h"

/*= INSTRUMENT TABLE
=====*/
/* address array: contains the GPIB addresses of opened instruments. */
/* bd array: contains the device descriptors returned by OpenDev. */
/* instr_cnt: contains the number of instruments open of this model type. */
/*=====*/
static int address[IF12_MAX_INSTR + 1];
static int bd[IF12_MAX_INSTR + 1];
static int instr_cnt;

/*= STATIC VARIABLES
=====*/
/* cmd is a buffer for GPIB I/O strings. */
/* if12_err: the error variable for the instrument module */
/* ibcnt: contains the number of bytes transferred by GPIB reads and */
/* writes. See the GPIB library I/O Class for more information */
/*=====*/
static char cmd[50];
static int if12_err;

/*= UTILITY ROUTINES
=====*/
int if12_open_instr (int, int *);
int if12_close_instr (int);
int if12_invalid_integer_range (int, int, int, int);
int if12_device_closed (int);
int if12_read_data (int, char *, int);
int if12_write_data (int, char *, int);
int if12_set_timeout (int, int, int *);
void if12_setup_arrays (void);

/*=====*/
/* Function: Initialize */
/* Purpose: This function opens the instrument, queries the instrument */
/* for its ID, and initializes the instrument to a known state. */

```

```

/*=====*/
int if12_init (addr, rest, instrID)
int addr;
int rest;
int *instrID;
{
    int ID;

    if (if12_invalid_integer_range (addr, 0, 30, -1) != 0)
        return if12_err;
    if (if12_invalid_integer_range (rest, 0, 1, -3) != 0)
        return if12_err;

    if (if12_open_instr (addr, &ID) != 0)
        return if12_err;

    if (rest) {
        if (if12_write_data (ID, "C", 1) != 0) {
            if12_close_instr (ID);
            return if12_err;
        }
        Delay(0.01);
    }
    if12_setup_arrays ();
    *instrID = ID;

    return if12_err;
}

/*=====*/
/* - Operations: Latch, Unlatch, Multiplex, Clear and Status --- */

int if12_operate (instrID, Operation, Module, Relay, Status)
int instrID, Operation, Module, Relay;
int *Status;
{
    char s[20];

    *Status = -1;
    if (Operation == 'C') {
        Fmt(s, "C");
        if (if12_write_data(instrID, s, StringLength(s)) != 0)
            return if12_err;
        Delay(0.01);
    }
    else {
        Fmt(s, "%c %d %d", Operation, Module, Relay);
    }
}

```

```

        if (if12_write_data(instrID, s, StringLength(s)) != 0)
            return if12_err;
    }
    if (if12_read_data(instrID, s, 2) != 0)
        return if12_err;
    *Status = s[0] & 0xf;
    return if12_err;
}

/*=====*/
/* Function: Write To Instrument */
/* Purpose: This function writes a command string to the instrument. */
/*=====*/
int if12_write (instrID, cmd_string)
int instrID;
char *cmd_string;
{
    if (if12_invalid_integer_range (instrID, 1, IF12_MAX_INSTR, -1) != 0)
        return if12_err;
    if (if12_device_closed(instrID) != 0)
        return if12_err;

    Fmt (cmd, "%s<%s", cmd_string);
    if (if12_write_data (instrID, cmd, NumFmtdBytes()) != 0)
        return if12_err;

    return if12_err;
}

/*=====*/
/* Function: Read Instrument Buffer */
/* Purpose: This function reads the output buffer of the instrument. */
/*=====*/
int if12_read (instrID, numbytes, in_buff, bytes_read)
int instrID;
int numbytes;
char *in_buff;
int *bytes_read;
{
    if (if12_invalid_integer_range (instrID, 1, IF12_MAX_INSTR, -1) != 0)
        return if12_err;
    if (if12_device_closed(instrID) != 0)
        return if12_err;

    *bytes_read = 0;
    if (if12_read_data (instrID, in_buff, numbytes) != 0)
        return if12_err;
}

```

```

        *bytes_read = ibcnt;

        return if12_err;
    }

/*=====*/
/* Function: Close */
/* Purpose: This function closes the instrument. */
/*=====*/
int if12_close (instrID)
int instrID;
{
    if (if12_invalid_integer_range (instrID, 1, IF12_MAX_INSTR, -1) != 0)
        return if12_err;
    if (if12_device_closed (instrID))
        return if12_err;

    if12_close_instr (instrID);

    return if12_err;
}

/*= UTILITY ROUTINES =====*/

/*=====*/
/* Function: Open Instrument */
/* Purpose: This function locates and initializes an entry in the */
/* Instrument Table and the GPIB device table for the */
/* instrument. The size of the Instrument Table can be changed */
/* in the include file by altering the constant */
/* IF12_MAX_INSTR. The return value of this function is equal */
/* to the global error variable. */
/*=====*/
int if12_open_instr (addr, ID)
int addr;
int *ID;
{
    int i, instrID;

    instrID = 0;
    if12_err = 0;

/* Check to see if the instrument is already in the Instrument Table. */

    for (i = 1; i <= IF12_MAX_INSTR; i++)
        if (address[i] == addr) {

```



```

        instrID = i;
        i = IF12_MAX_INSTR;
    }

```

/* If it is not in the instrument table, open an entry for the instrument. */

```

    if (instrID <= 0)
        for (i = 1; i <= IF12_MAX_INSTR; i++)
            if (address[i] == 0) {
                instrID = i;
                i = IF12_MAX_INSTR;
            }

```

/* If an entry could not be opened in the Instrument Table, return an error.*/

```

    if (instrID <= 0) {
        if12_err = 220;
        return if12_err;
    }

```

/* If the device has not been opened in the GPIB device table (bd[ID] = 0),*/
/* then open it. */

```

    if (bd[instrID] <= 0) {
        if (instr_cnt <= 0)
            CloseInstrDevs("if12");
        bd[instrID] = OpenDev ("", "if12");
        if (bd[instrID] <= 0) {
            if12_err = 220;
            return if12_err;
        }
        instr_cnt += 1;
        address[instrID] = addr;
    }

```

/* Change the primary address of the device */

```

    if (ibpad (bd[instrID], addr) < 0) {
        if12_err = 233;
        return if12_err;
    }

```

```

    *ID = instrID;
    return if12_err;

```

```

}

```

/*=====*/

```

/* Function: Close Instrument                                     */
/* Purpose: This function closes the instrument by removing it from the */
/*          GPIB device table and setting the address and bd[instrID] to */
/*          zero in the Instrument Table. The return value is equal to */
/*          the global error variable.                               */
/*=====*/
int if12_close_instr (instrID)
int instrID;
{
    if (bd[instrID] != 0) {
        CloseDev (bd[instrID]);
        bd[instrID] = 0;
        address[instrID] = 0;
        instr_cnt -= 1;
    }
    else
        if12_err = 221;

    return if12_err;
}

/*=====*/
/* Function: Invalid Integer Range                               */
/* Purpose: This function checks an integer to see if it lies between a */
/*          minimum and maximum value. If the value is out of range, set */
/*          the global error variable to the value err_code. If the */
/*          value is OK, error = 0. The return value is equal to the */
/*          global error value.                                   */
/*=====*/
int if12_invalid_integer_range (val, min, max, err_code)
int val;
int min;
int max;
int err_code;
{
    if (val < min || val > max)
        if12_err = err_code;
    else
        if12_err = 0;

    return if12_err;
}

/*=====*/
/* Function: Device Closed                                     */
/* Purpose: This function checks to see if the module has been */
/*          initialized. If the device has not been opened, set the */

```

```

/*      global error variable to 232, 0 otherwise. The return value  */
/*      is equal to the global error value.                          */
/*=====*/
int if12_device_closed (instrID)
int instrID;
{
    if (bd[instrID] <= 0)
        if12_err = 232;
    else
        if12_err = 0;

    return if12_err;
}

/*=====*/
/* Function: Read Data                                             */
/* Purpose: This function reads a buffer of data from the instrument. The */
/*      return value is equal to the global error variable.      */
/*=====*/
int if12_read_data (instrID, buf, cnt)
int instrID;
char *buf;
int cnt;
{
    if (ibrd(bd[instrID], buf, (long)cnt) <= 0)
        if12_err = 231;
    else
        if12_err = 0;

    return if12_err;
}

/*=====*/
/* Function: Write Data                                           */
/* Purpose: This function writes a buffer of data to the instrument. The */
/*      return value is equal to the global error variable.      */
/*=====*/
int if12_write_data (instrID, buf, cnt)
int instrID;
char *buf;
int cnt;
{
    if (ibwrt(bd[instrID], buf, (long)cnt) <= 0)
        if12_err = 230;
    else
        if12_err = 0;
}

```

```

        return if12_err;
    }

/*=====*/
/* Function: Set Timeout */
/* Purpose: This function changes or disables the timeout of the device. */
/* Refer to the LabWindows Standard Libraries Reference Manual */
/* for timeout codes. The return value is equal to the global */
/* error variable. */
/*=====*/
int if12_set_timeout (instrID, tmo_code, old_timeout)
int instrID;
int tmo_code;
int *old_timeout;
{
    *old_timeout = ibtmo (bd[instrID], tmo_code);
    if (ibsta <= 0)
        if12_err = 239;
    else
        if12_err = 0;

    return if12_err;
}

/*=====*/
/* Function: Setup Arrays */
/* Purpose: This function is called by the init routine to initialize */
/* static arrays. */
/* This routine should be modified for each instrument to */
/* include instrument-dependent commmand arrays. */
/*=====*/
void if12_setup_arrays ()
{
}
/*==== THE END =====*/

```

LabView Drivers

Labview Drivers are available for download at <https://cytec-ate.com/downloads/drivers/>

MAIN CONTROLLER

SHEET 2

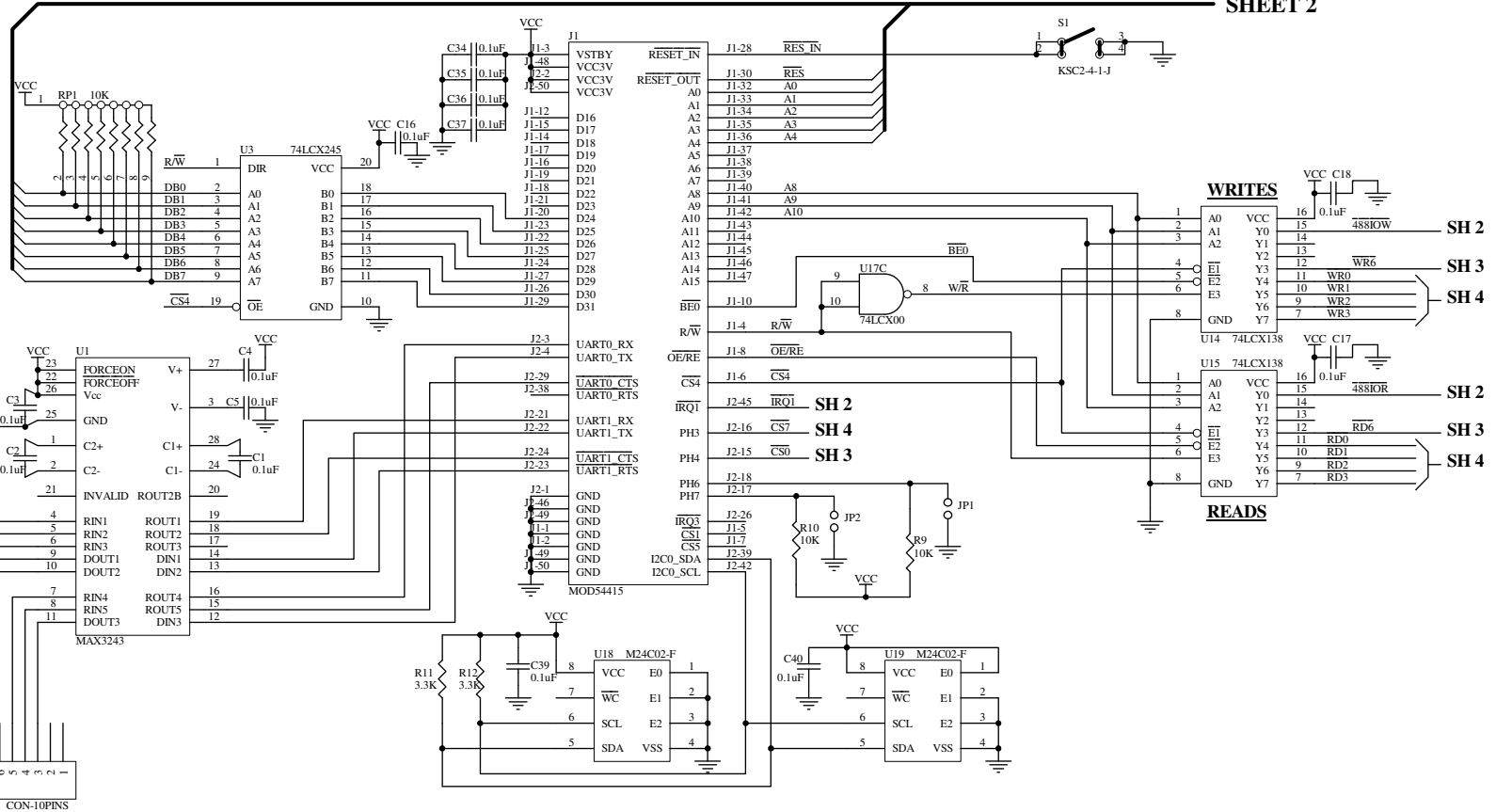

RS232 Control

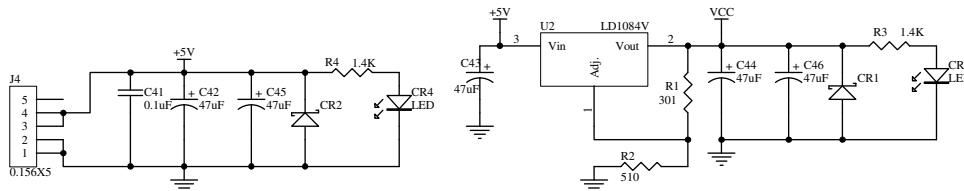
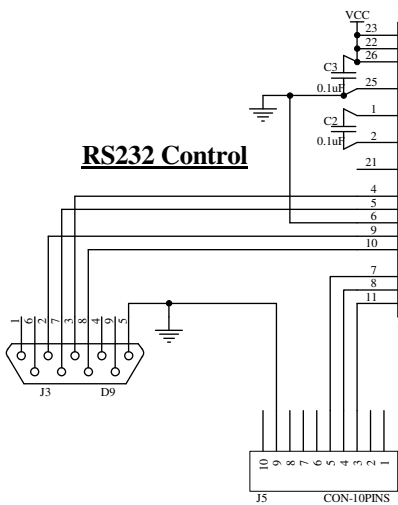

APPROVED BY	DRAWING NUMBER	DRAWN BY: KJA
DATE: 24-Oct-2022	11-21-50/01	REVISION: -
SIZE: B	TITLE: IF-12 Mainframe Ctrl Module	
11-21-50-01.sch		SHEET 1 OF 4

SHEET 1

SHEET 3

IEEE488 CONTROL

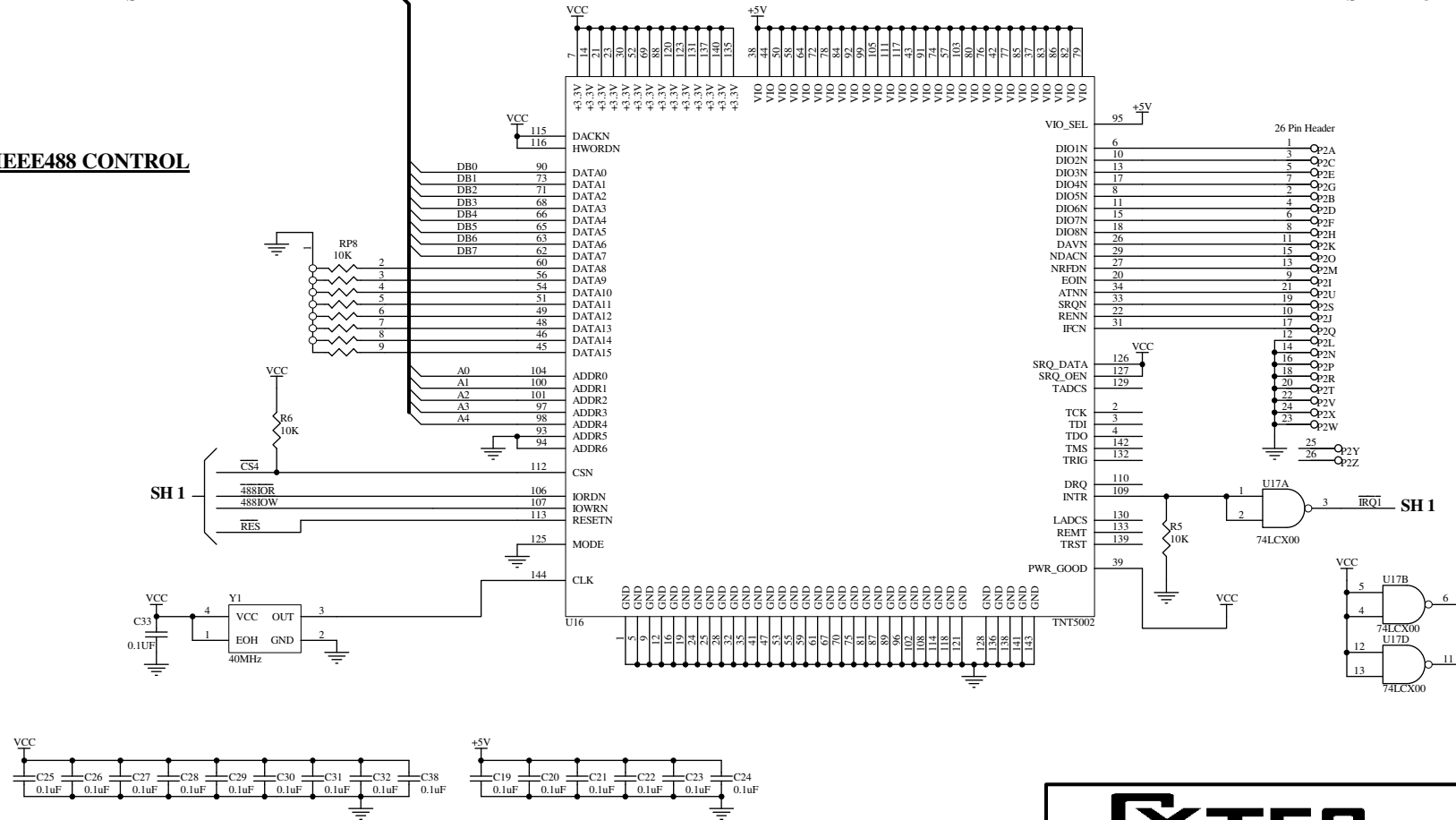

APPROVED BY	DRAWING NUMBER	DRAWN BY: KJA
DATE: 24-Oct-2022	11-21-50/02	REVISION: -
SIZE: B	TITLE: IF-12 Mainframe Ctrl Module	
11-21-50-02.sch		SHEET 2 OF 4

SHEET 2

SHEET 4

LCD CTRL

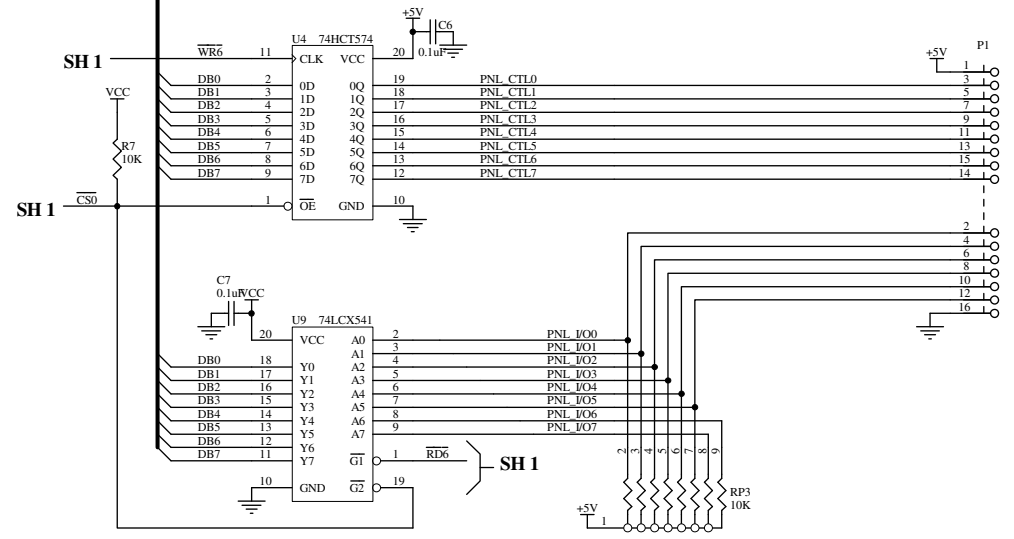

FRONT PANEL
INTERFACE
HEADER



APPROVED BY	DRAWING NUMBER	DRAWN BY: KJA
DATE: 24-Oct-2022	11-21-50/03	REVISION: -
SIZE: B	TITLE: IF-12 Mainframe Ctrl Module	
11-21-50-03.sch		SHEET 3 OF 4

SHEET 3

SH 1

SH 1

SH 1

SH 1

CONTROL

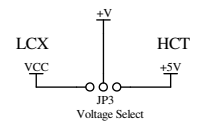

YTEC CORP.

APPROVED BY	DRAWING NUMBER	DRAWN BY: KJA
DATE: 24-Oct-2022	11-21-50/04	REVISION: -
SIZE: B	TITLE: IF-12 Mainframe Ctrl Module	
11-21-50-04.sch		SHEET 4 OF 4

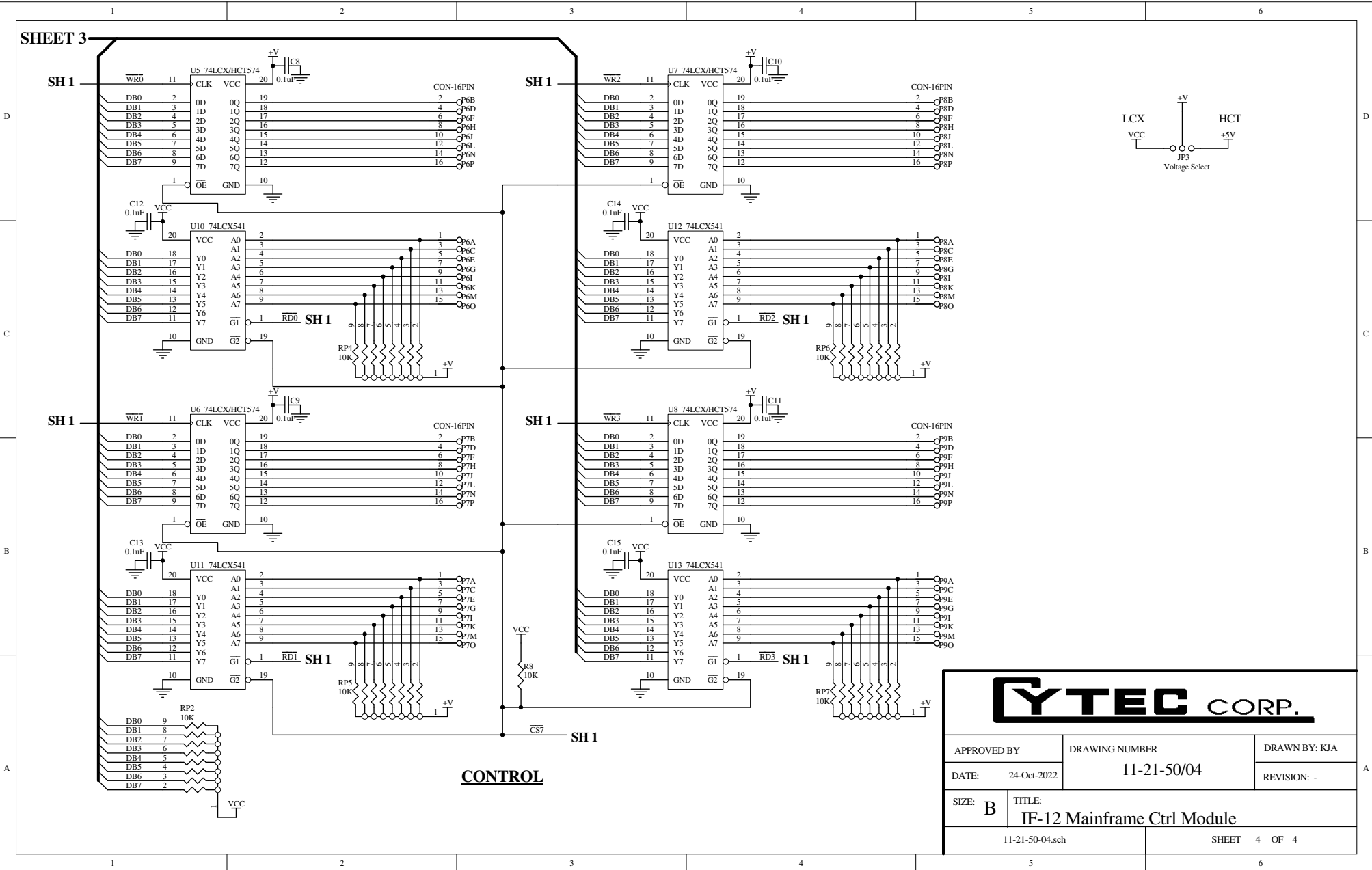

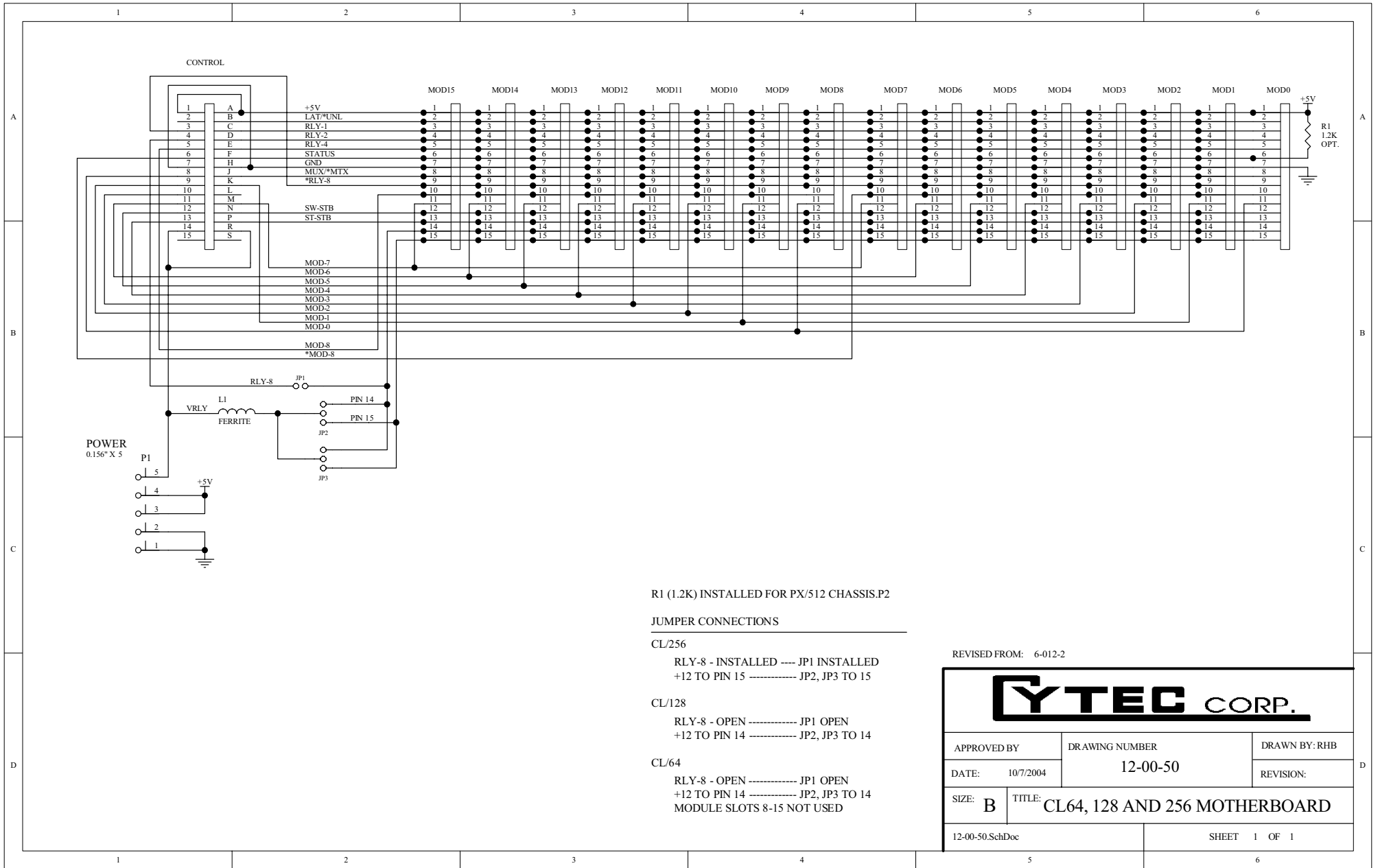

R1 (1.2K) INSTALLED FOR PX/512 CHASSIS.P2

JUMPER CONNECTIONS

CL/256

RLY-8 - INSTALLED ---- JP1 INSTALLED
 +12 TO PIN 15 ----- JP2, JP3 TO 15

CL/128

RLY-8 - OPEN ----- JP1 OPEN
 +12 TO PIN 14 ----- JP2, JP3 TO 14

CL/64

RLY-8 - OPEN ----- JP1 OPEN
 +12 TO PIN 14 ----- JP2, JP3 TO 14
 MODULE SLOTS 8-15 NOT USED

REVISED FROM: 6-012-2

YTEC CORP.		
APPROVED BY	DRAWING NUMBER	DRAWN BY: RHB
DATE: 10/7/2004	12-00-50	REVISION:
SIZE: B	TITLE: CL64, 128 AND 256 MOTHERBOARD	
12-00-50.SchDoc		SHEET 1 OF 1

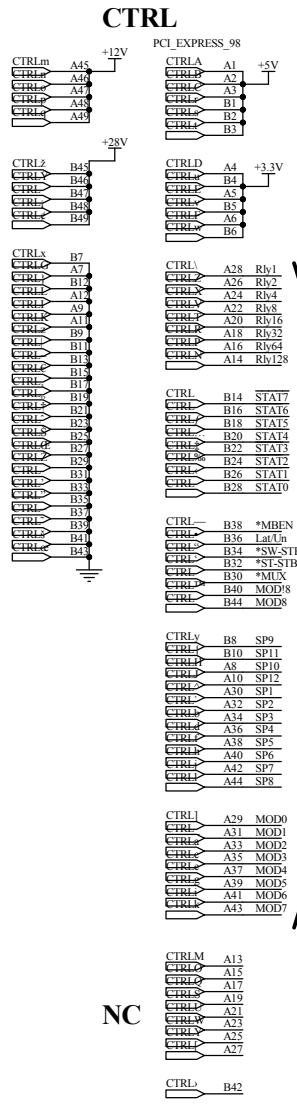
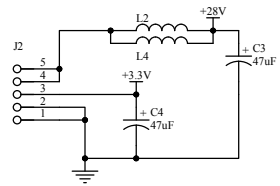
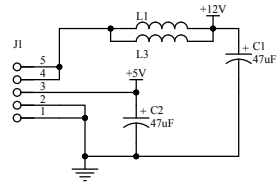

TO SHEETS 2 AND 3

REVISED FROM:

RYTEC CORP.		
APPROVED BY	DRAWING NUMBER	DRAWN BY: KJA
DATE: 2-Dec-2013	12-01-50/01	REVISION:
SIZE: A3	TITLE: CP64, 128 AND 256 MOTHERBOARD	
12-01-50-01.SCH	SHEET 1 OF 3	

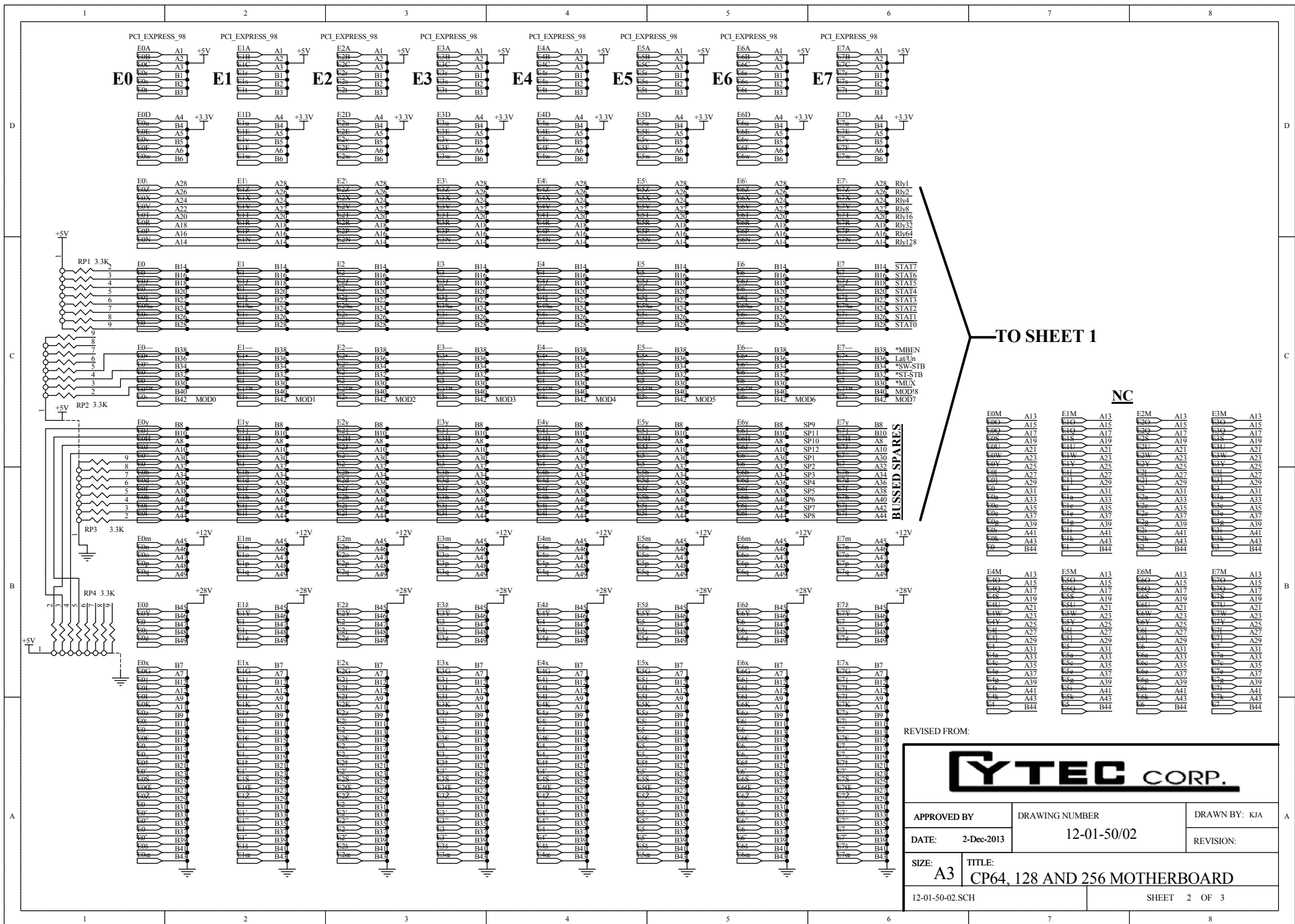

TO SHEET 1

NC

E0M		E1M		E2M		E3M	
E0M	A13	E1M	A13	E2M	A13	E3M	A13
E0M	A15	E1M	A15	E2M	A15	E3M	A15
E0M	A17	E1M	A17	E2M	A17	E3M	A17
E0M	A19	E1M	A19	E2M	A19	E3M	A19
E0M	A21	E1M	A21	E2M	A21	E3M	A21
E0M	A23	E1M	A23	E2M	A23	E3M	A23
E0M	A25	E1M	A25	E2M	A25	E3M	A25
E0M	A27	E1M	A27	E2M	A27	E3M	A27
E0M	A29	E1M	A29	E2M	A29	E3M	A29
E0M	A31	E1M	A31	E2M	A31	E3M	A31
E0M	A33	E1M	A33	E2M	A33	E3M	A33
E0M	A35	E1M	A35	E2M	A35	E3M	A35
E0M	A37	E1M	A37	E2M	A37	E3M	A37
E0M	A39	E1M	A39	E2M	A39	E3M	A39
E0M	A41	E1M	A41	E2M	A41	E3M	A41
E0M	A43	E1M	A43	E2M	A43	E3M	A43
E0M	B44	E1M	B44	E2M	B44	E3M	B44

E4M		E5M		E6M		E7M	
E4M	A13	E5M	A13	E6M	A13	E7M	A13
E4M	A15	E5M	A15	E6M	A15	E7M	A15
E4M	A17	E5M	A17	E6M	A17	E7M	A17
E4M	A19	E5M	A19	E6M	A19	E7M	A19
E4M	A21	E5M	A21	E6M	A21	E7M	A21
E4M	A23	E5M	A23	E6M	A23	E7M	A23
E4M	A25	E5M	A25	E6M	A25	E7M	A25
E4M	A27	E5M	A27	E6M	A27	E7M	A27
E4M	A29	E5M	A29	E6M	A29	E7M	A29
E4M	A31	E5M	A31	E6M	A31	E7M	A31
E4M	A33	E5M	A33	E6M	A33	E7M	A33
E4M	A35	E5M	A35	E6M	A35	E7M	A35
E4M	A37	E5M	A37	E6M	A37	E7M	A37
E4M	A39	E5M	A39	E6M	A39	E7M	A39
E4M	A41	E5M	A41	E6M	A41	E7M	A41
E4M	A43	E5M	A43	E6M	A43	E7M	A43
E4M	B44	E5M	B44	E6M	B44	E7M	B44

REVISED FROM:



APPROVED BY	DRAWING NUMBER	DRAWN BY: KJA
DATE: 2-Dec-2013	12-01-50/02	REVISION:
SIZE: A3	TITLE: CP64, 128 AND 256 MOTHERBOARD	
12-01-50-02.SCH	SHEET 2 OF 3	

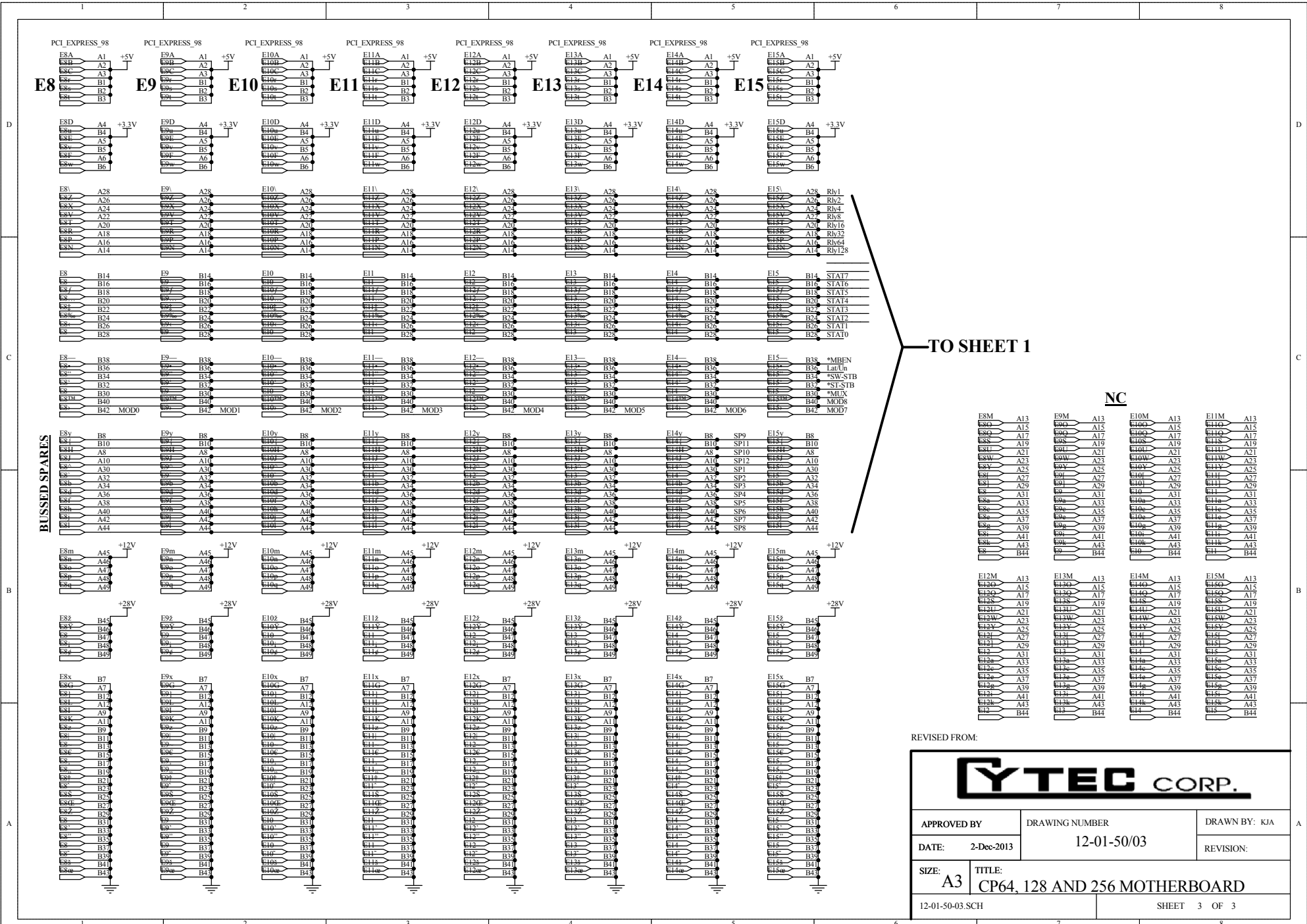

TO SHEET 1

NC

E8M	A13	E9M	A13	E10M	A13	E11M	A13
E8N	A15	E9N	A15	E10N	A15	E11N	A15
E8P	A17	E9P	A17	E10P	A17	E11P	A17
E8Q	A19	E9Q	A19	E10Q	A19	E11Q	A19
E8R	A21	E9R	A21	E10R	A21	E11R	A21
E8S	A23	E9S	A23	E10S	A23	E11S	A23
E8T	A25	E9T	A25	E10T	A25	E11T	A25
E8U	A27	E9U	A27	E10U	A27	E11U	A27
E8V	A29	E9V	A29	E10V	A29	E11V	A29
E8W	A31	E9W	A31	E10W	A31	E11W	A31
E8X	A33	E9X	A33	E10X	A33	E11X	A33
E8Y	A35	E9Y	A35	E10Y	A35	E11Y	A35
E8Z	A37	E9Z	A37	E10Z	A37	E11Z	A37
E8A	A39	E9A	A39	E10A	A39	E11A	A39
E8B	A41	E9B	A41	E10B	A41	E11B	A41
E8C	A43	E9C	A43	E10C	A43	E11C	A43
E8D	B44	E9D	B44	E10D	B44	E11D	B44
E12M	A13	E13M	A13	E14M	A13	E15M	A13
E12N	A15	E13N	A15	E14N	A15	E15N	A15
E12P	A17	E13P	A17	E14P	A17	E15P	A17
E12Q	A19	E13Q	A19	E14Q	A19	E15Q	A19
E12R	A21	E13R	A21	E14R	A21	E15R	A21
E12S	A23	E13S	A23	E14S	A23	E15S	A23
E12T	A25	E13T	A25	E14T	A25	E15T	A25
E12U	A27	E13U	A27	E14U	A27	E15U	A27
E12V	A29	E13V	A29	E14V	A29	E15V	A29
E12W	A31	E13W	A31	E14W	A31	E15W	A31
E12X	A33	E13X	A33	E14X	A33	E15X	A33
E12Y	A35	E13Y	A35	E14Y	A35	E15Y	A35
E12Z	A37	E13Z	A37	E14Z	A37	E15Z	A37
E12A	A39	E13A	A39	E14A	A39	E15A	A39
E12B	A41	E13B	A41	E14B	A41	E15B	A41
E12C	A43	E13C	A43	E14C	A43	E15C	A43
E12D	B44	E13D	B44	E14D	B44	E15D	B44

REVISED FROM:

RYTEC CORP.		
APPROVED BY	DRAWING NUMBER	DRAWN BY: KJA
DATE: 2-Dec-2013	12-01-50/03	REVISION:
SIZE: A3	TITLE: CP64, 128 AND 256 MOTHERBOARD	
12-01-50-03.SCH	SHEET 3 OF 3	

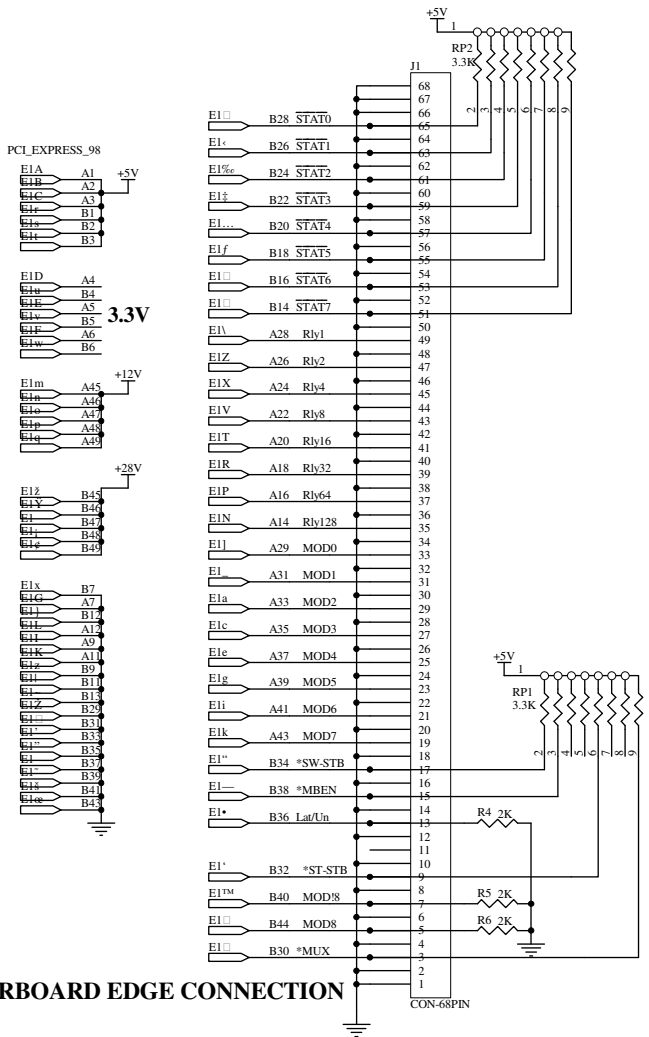
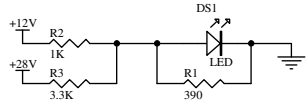

MOTHERBOARD EDGE CONNECTION



APPROVED BY	DRAWING NUMBER	DRAWN BY: KJA
DATE: 16-Jul-2019	12-04-50	REVISION: -
SIZE: B	TITLE: 68 PIN CP ADAPTER CARD	
12-04-50.SCH	SHEET 1 OF 1	

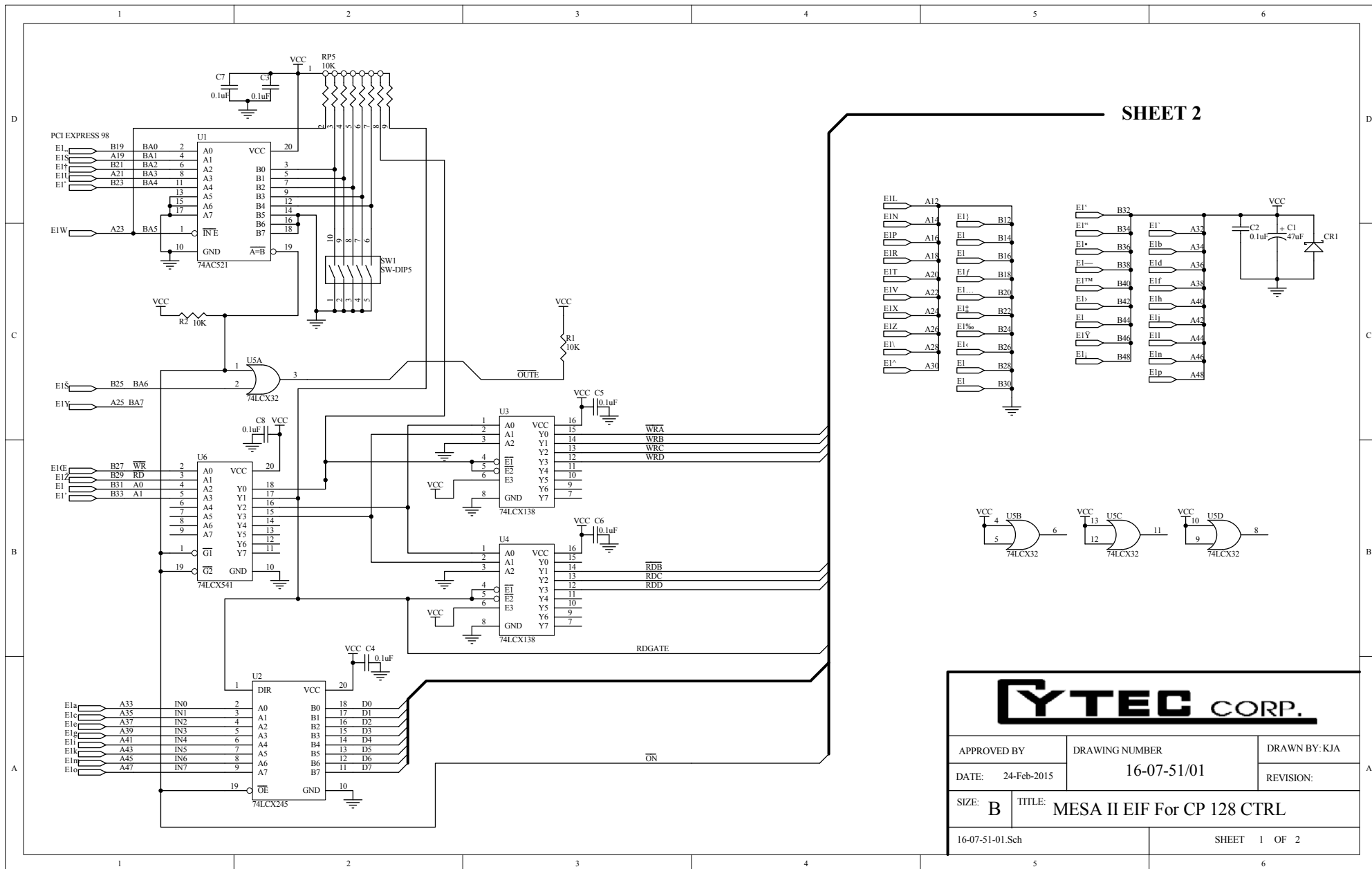

SHEET 1

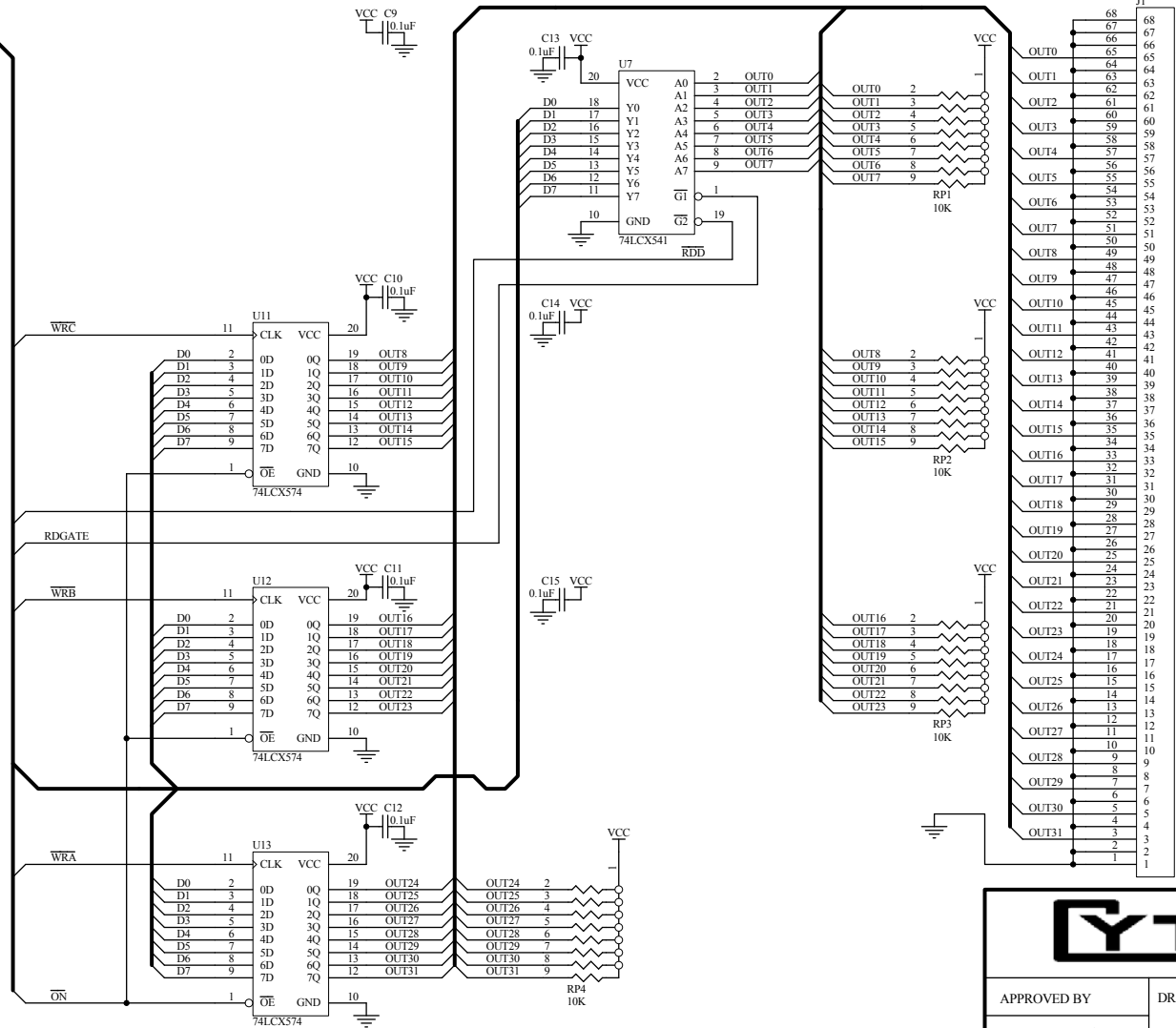

3M 61068 Right Angle



APPROVED BY	DRAWING NUMBER	DRAWN BY: KJA
DATE: 24-Feb-2015	16-07-51/02	REVISION:
SIZE: B	TITLE: MESA II EIF For CP 128 CTRL	
16-07-51-02.Sch		SHEET 2 OF 2

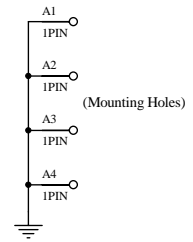
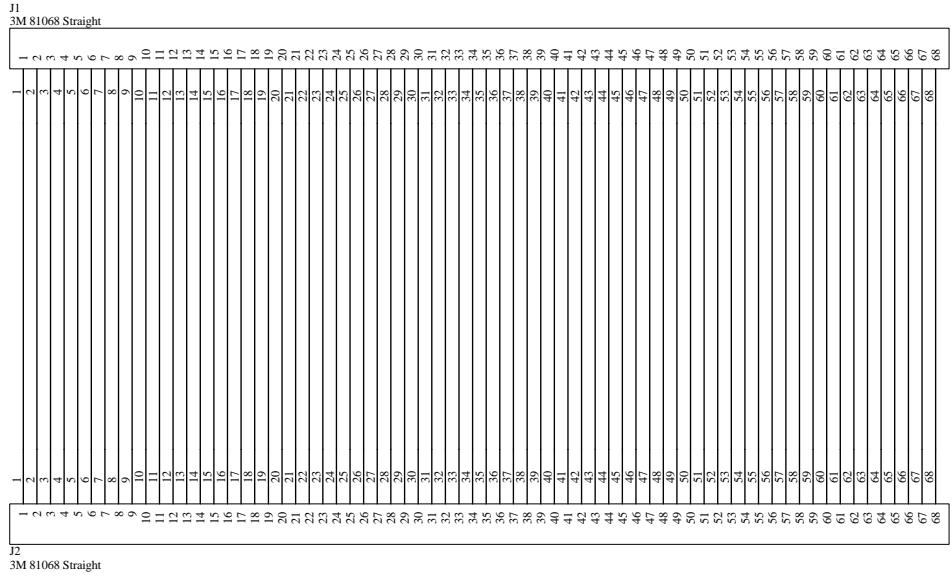
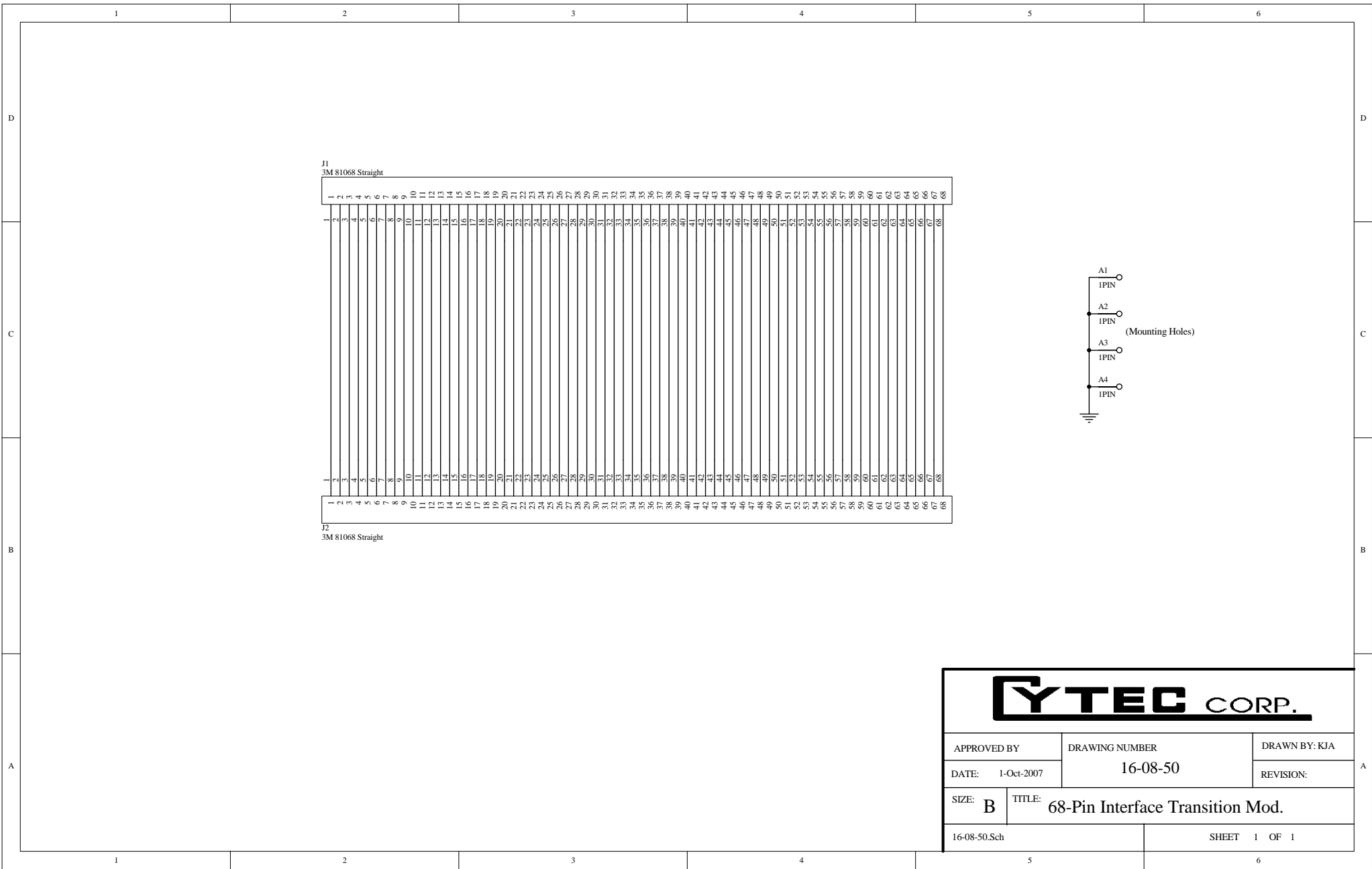

YTEC CORP.		
APPROVED BY	DRAWING NUMBER	DRAWN BY: KJA
DATE: 1-Oct-2007	16-08-50	REVISION:
SIZE: B	TITLE: 68-Pin Interface Transition Mod.	
16-08-50.Sch		SHEET 1 OF 1

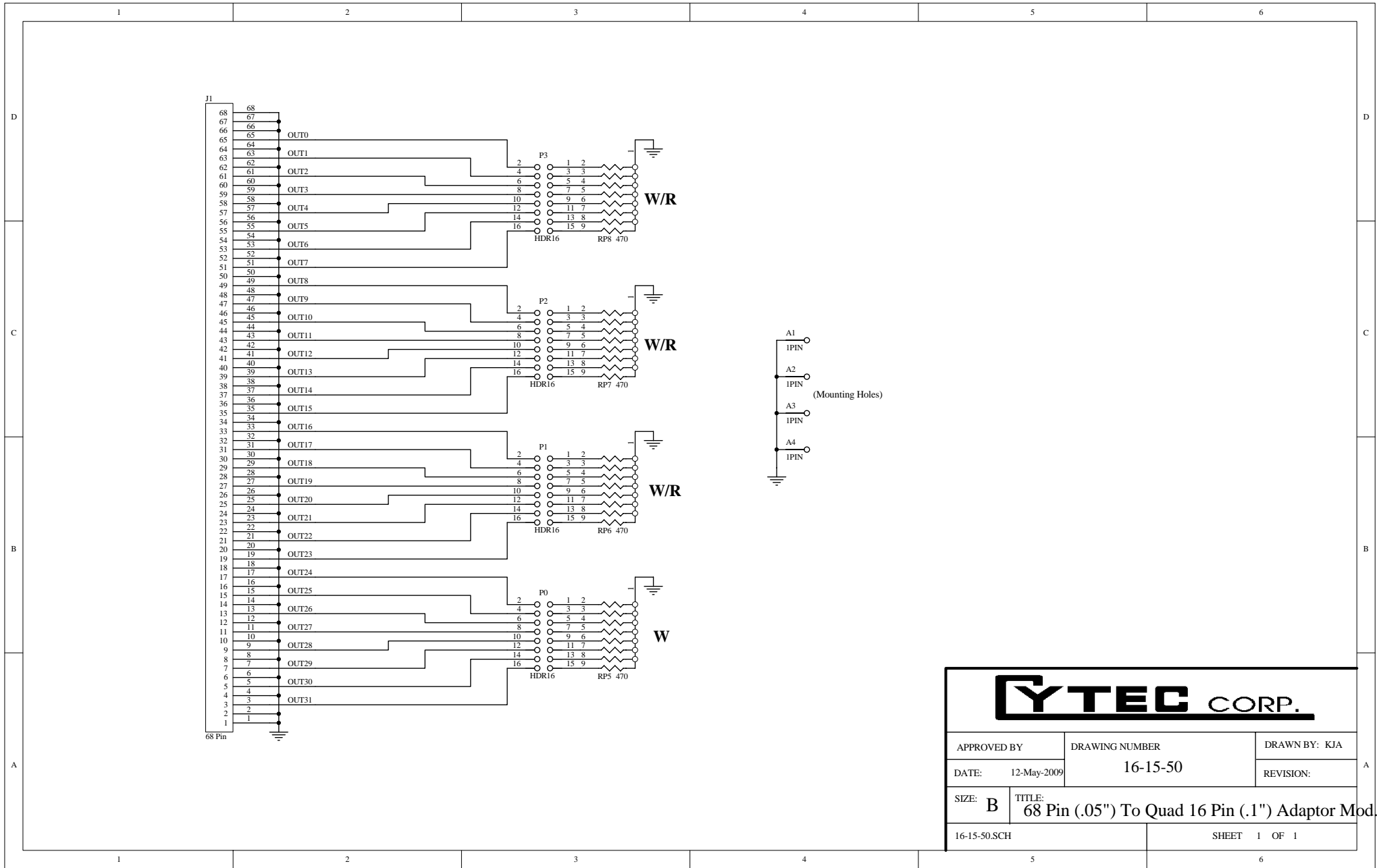

YTEC CORP.		
APPROVED BY	DRAWING NUMBER	DRAWN BY: KJA
DATE: 12-May-2009	16-15-50	REVISION:
SIZE: B	TITLE: 68 Pin (.05") To Quad 16 Pin (.1") Adaptor Mod.	
16-15-50.SCH		SHEET 1 OF 1

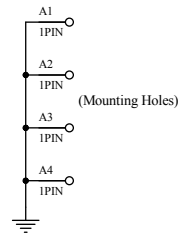
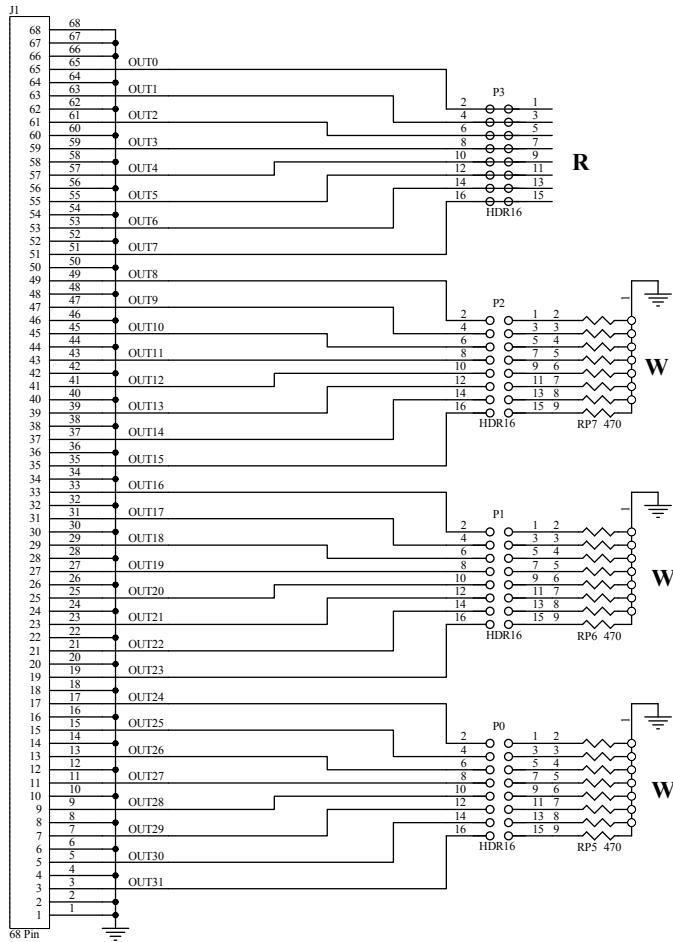

YTEC CORP.		
APPROVED BY	DRAWING NUMBER	DRAWN BY: KJA
DATE: 13-Jan-2014	16-15-51	REVISION:
SIZE: B	TITLE: 68 Pin To Quad 16 Pin Mod. (24W/8R)	
16-15-51.SCH	SHEET 1 OF 1	

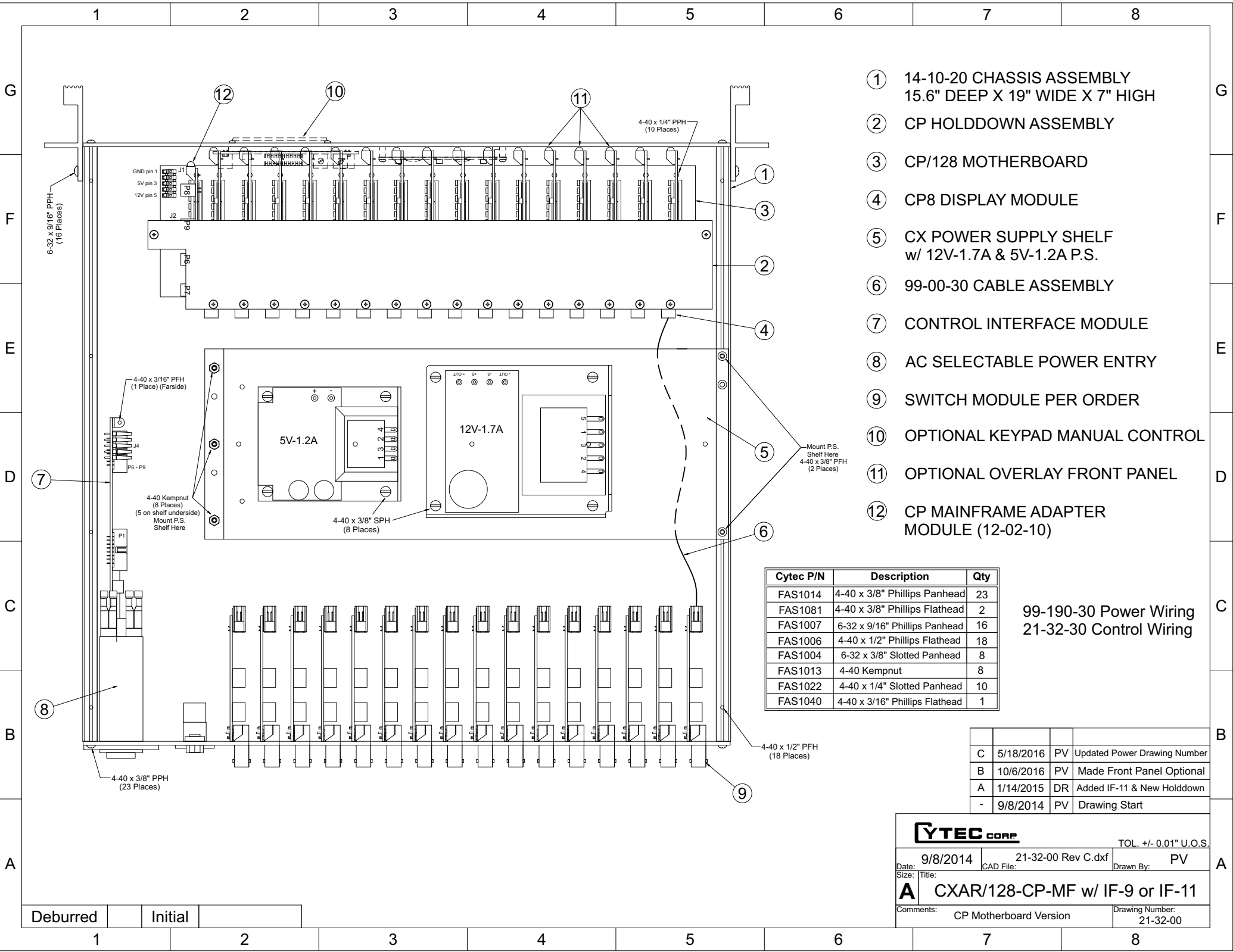

- ① 14-10-20 CHASSIS ASSEMBLY
15.6" DEEP X 19" WIDE X 7" HIGH
- ② CP HOLDDOWN ASSEMBLY
- ③ CP/128 MOTHERBOARD
- ④ CP8 DISPLAY MODULE
- ⑤ CX POWER SUPPLY SHELF
w/ 12V-1.7A & 5V-1.2A P.S.
- ⑥ 99-00-30 CABLE ASSEMBLY
- ⑦ CONTROL INTERFACE MODULE
- ⑧ AC SELECTABLE POWER ENTRY
- ⑨ SWITCH MODULE PER ORDER
- ⑩ OPTIONAL KEYPAD MANUAL CONTROL
- ⑪ OPTIONAL OVERLAY FRONT PANEL
- ⑫ CP MAINFRAME ADAPTER
MODULE (12-02-10)

Cytec P/N	Description	Qty
FAS1014	4-40 x 3/8" Phillips Panhead	23
FAS1081	4-40 x 3/8" Phillips Flathead	2
FAS1007	6-32 x 9/16" Phillips Panhead	16
FAS1006	4-40 x 1/2" Phillips Flathead	18
FAS1004	6-32 x 3/8" Slotted Panhead	8
FAS1013	4-40 Kempnut	8
FAS1022	4-40 x 1/4" Slotted Panhead	10
FAS1040	4-40 x 3/16" Phillips Flathead	1

99-190-30 Power Wiring
21-32-30 Control Wiring

C	5/18/2016	PV	Updated Power Drawing Number
B	10/6/2016	PV	Made Front Panel Optional
A	1/14/2015	DR	Added IF-11 & New Holddown
-	9/8/2014	PV	Drawing Start

CYTEC CORP. TOL. +/- 0.01" U.O.S.

Date: 9/8/2014 CAD File: 21-32-00 Rev C.dxf Drawn By: PV

Size: Title: **A** CXAR/128-CP-MF w/ IF-9 or IF-11

Comments: CP Motherboard Version Drawing Number: 21-32-00

Deburred Initial

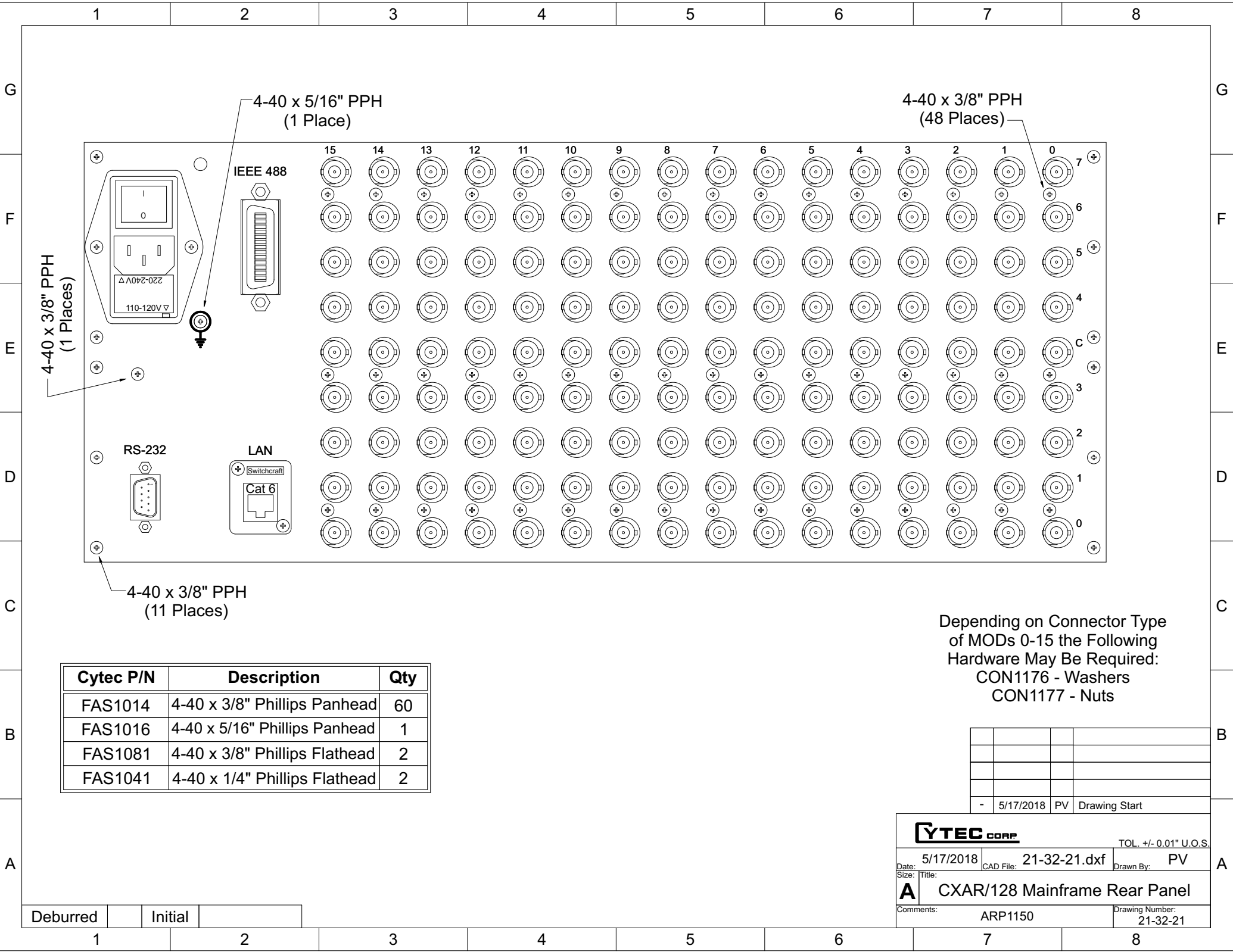

4-40 x 5/16" PPH
(1 Place)

4-40 x 3/8" PPH
(48 Places)

4-40 x 3/8" PPH
(1 Place)

RS-232

LAN
[Switchcraft]
Cat 6

4-40 x 3/8" PPH
(11 Places)

Depending on Connector Type
of MODs 0-15 the Following
Hardware May Be Required:
CON1176 - Washers
CON1177 - Nuts

Cytec P/N	Description	Qty
FAS1014	4-40 x 3/8" Phillips Panhead	60
FAS1016	4-40 x 5/16" Phillips Panhead	1
FAS1081	4-40 x 3/8" Phillips Flathead	2
FAS1041	4-40 x 1/4" Phillips Flathead	2

-	5/17/2018	PV	Drawing Start

YTEC CORP. TOL. +/- 0.01" U.O.S.

Date: 5/17/2018 CAD File: 21-32-21.dxf Drawn By: PV

Size: Title: **A** CXAR/128 Mainframe Rear Panel

Comments: ARP1150 Drawing Number: 21-32-21

Deburred		Initial	
----------	--	---------	--

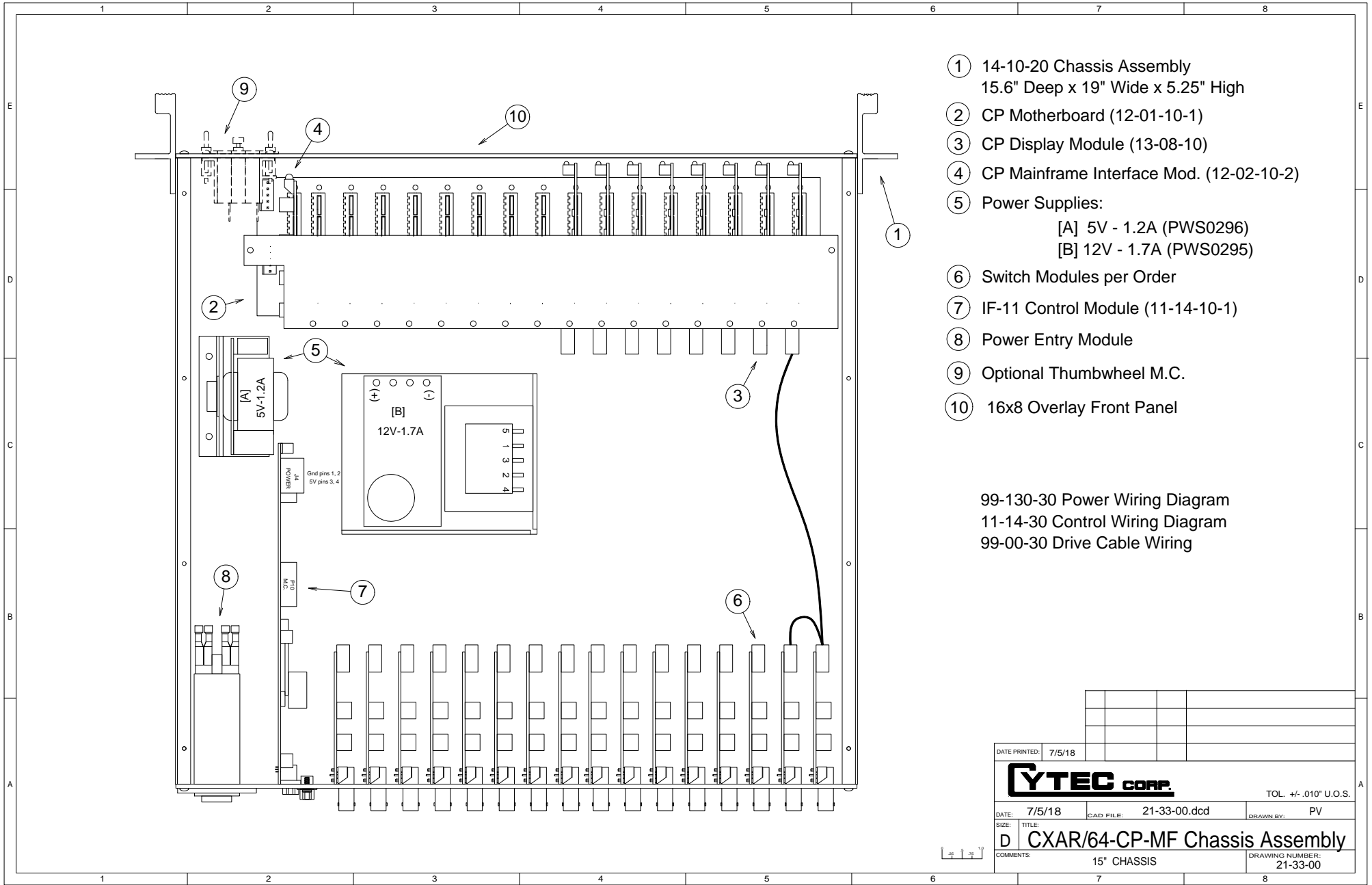

- ① 14-10-20 Chassis Assembly
15.6" Deep x 19" Wide x 5.25" High
- ② CP Motherboard (12-01-10-1)
- ③ CP Display Module (13-08-10)
- ④ CP Mainframe Interface Mod. (12-02-10-2)
- ⑤ Power Supplies:
[A] 5V - 1.2A (PWS0296)
[B] 12V - 1.7A (PWS0295)
- ⑥ Switch Modules per Order
- ⑦ IF-11 Control Module (11-14-10-1)
- ⑧ Power Entry Module
- ⑨ Optional Thumbwheel M.C.
- ⑩ 16x8 Overlay Front Panel

99-130-30 Power Wiring Diagram
 11-14-30 Control Wiring Diagram
 99-00-30 Drive Cable Wiring

DATE PRINTED: 7/5/18		TOL. +/- .010" U.O.S.	
YTEC CORP.			
DATE: 7/5/18	CAD FILE: 21-33-00.dcd	DRAWN BY: PV	
SIZE: D	TITLE: CXAR/64-CP-MF Chassis Assembly		DRAWING NUMBER: 21-33-00
COMMENTS: 15" CHASSIS			

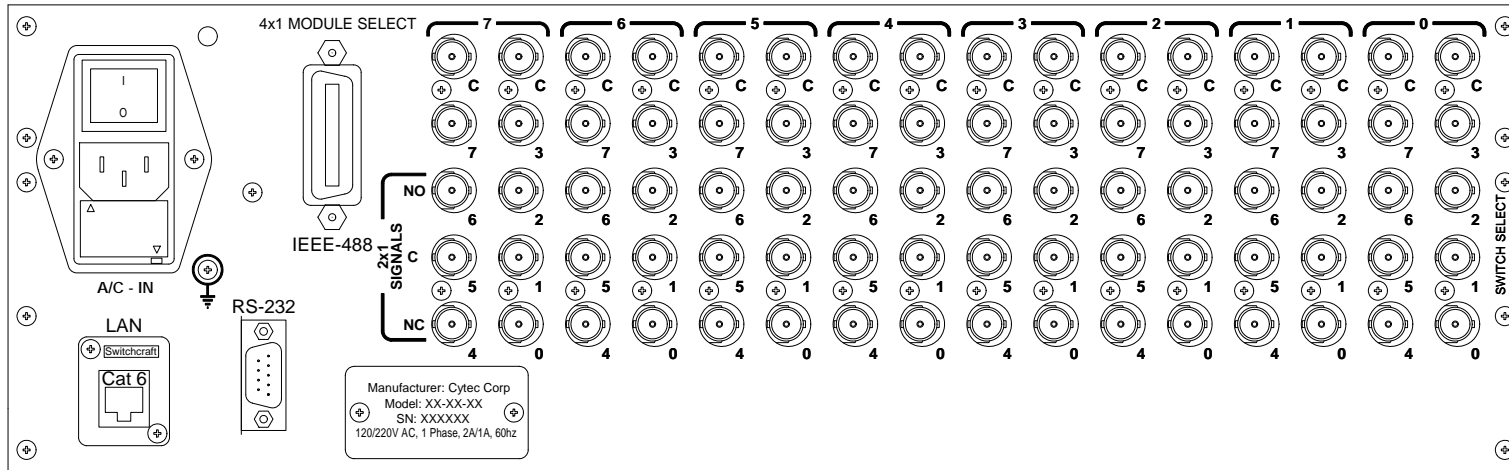

DEEP ETCH & CLEAR ANODIZE

PRINTED ON:	7/18/18			
CYTEC CORP.				
				TOL. +/- .010" U.O.S.
DATE:	7/2/18	CAD FILE:	21-33-21.dcd	DRAWN BY:
SIZE:	C	TITLE:	CXAR/64-CP-MF Rear Panel	
COMMENTS:	ARP1152			DRAWING NUMBER:
				21-33-21

16 PIN DIP

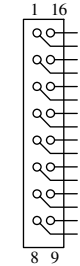

16 PIN HEADER

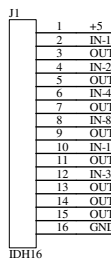

PUSHWHEELS ADDED LS TO MS AS REQUIRED

MS(LEFTMOST DIGITS)

LS(RIGHTMOST DIGITS)

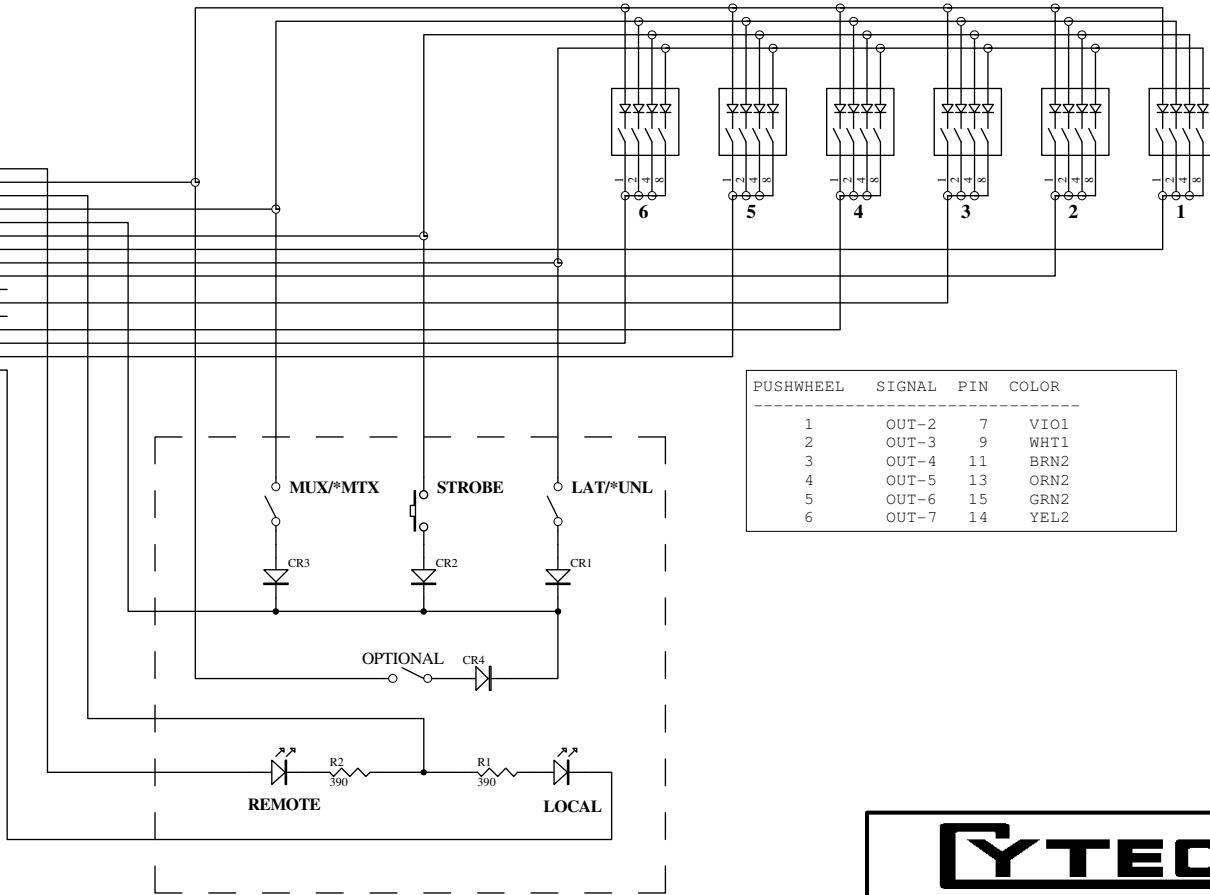

PUSHWHEEL	SIGNAL	PIN	COLOR
1	OUT-2	7	VIO1
2	OUT-3	9	WHT1
3	OUT-4	11	BRN2
4	OUT-5	13	ORN2
5	OUT-6	15	GRN2
6	OUT-7	14	YEL2

YTEC CORP.

APPROVED BY	DRAWING NUMBER	DRAWN BY: KJA
DATE: 23-Apr-2019	90-81-50	REVISION: -
SIZE: B	TITLE: PUSHWHEEL FRONT PANEL	
90-81-50.SCH		SHEET 1 OF 1

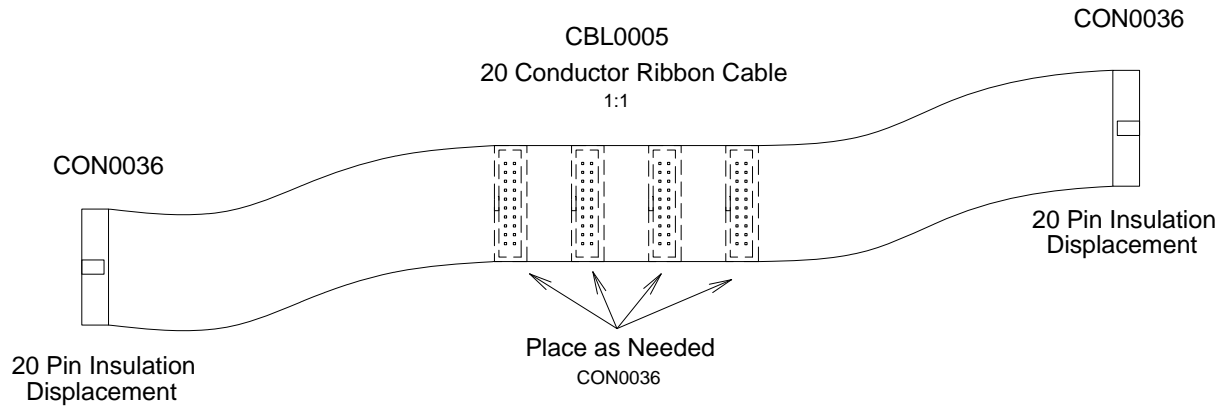
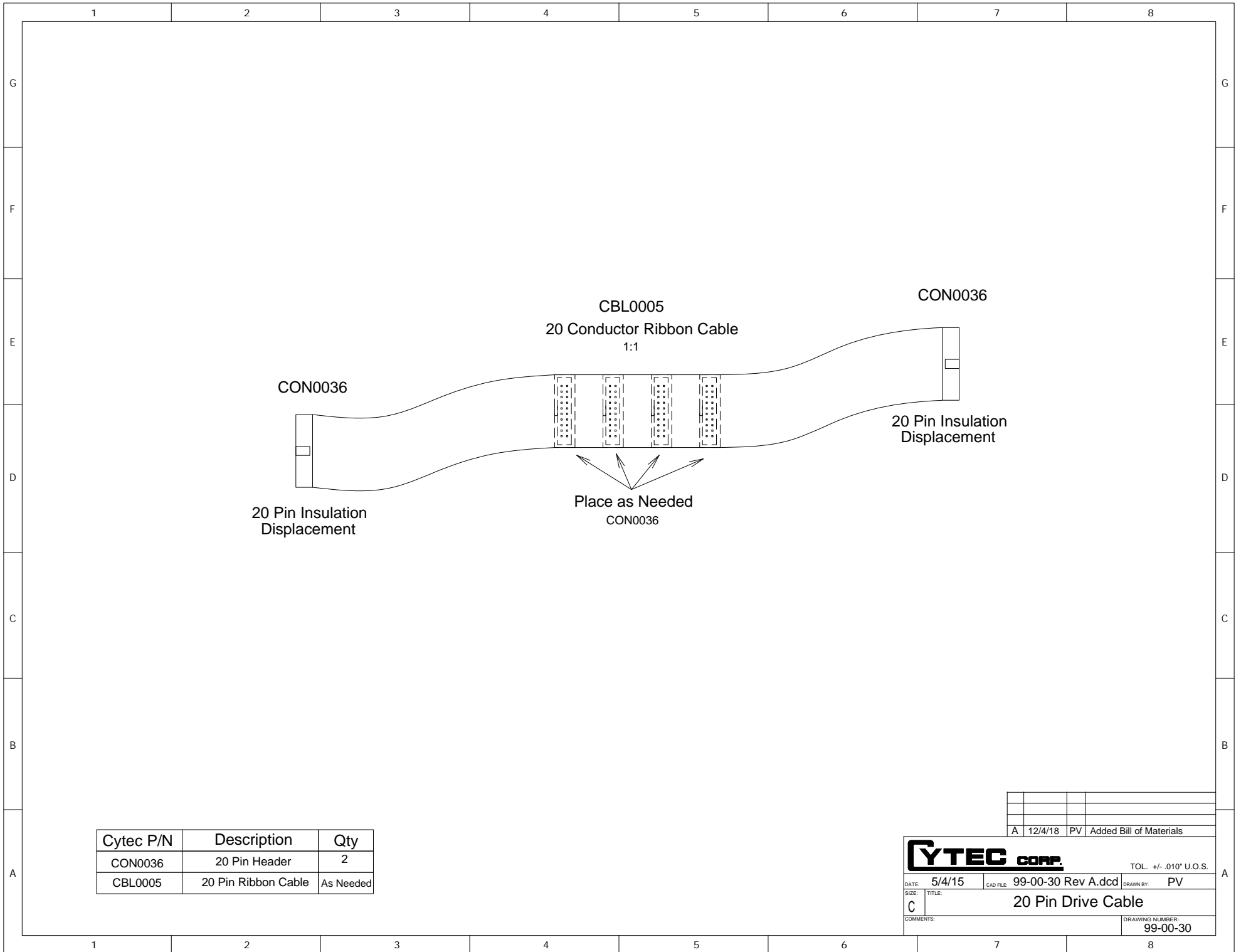

Cytec P/N	Description	Qty
CON0036	20 Pin Header	2
CBL0005	20 Pin Ribbon Cable	As Needed

A	12/4/18	PV	Added Bill of Materials

CYTEC CORP. TOL. +/- .010" U.O.S.

DATE: 5/4/15 CAD FILE: 99-00-30 Rev A.dcd DRAWN BY: PV

SIZE: C TITLE: 20 Pin Drive Cable

COMMENTS: DRAWING NUMBER: 99-00-30

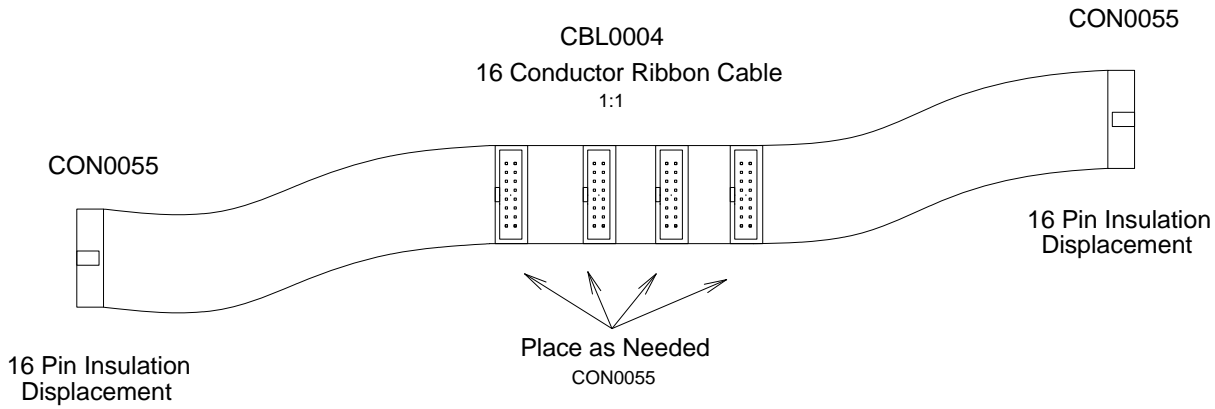
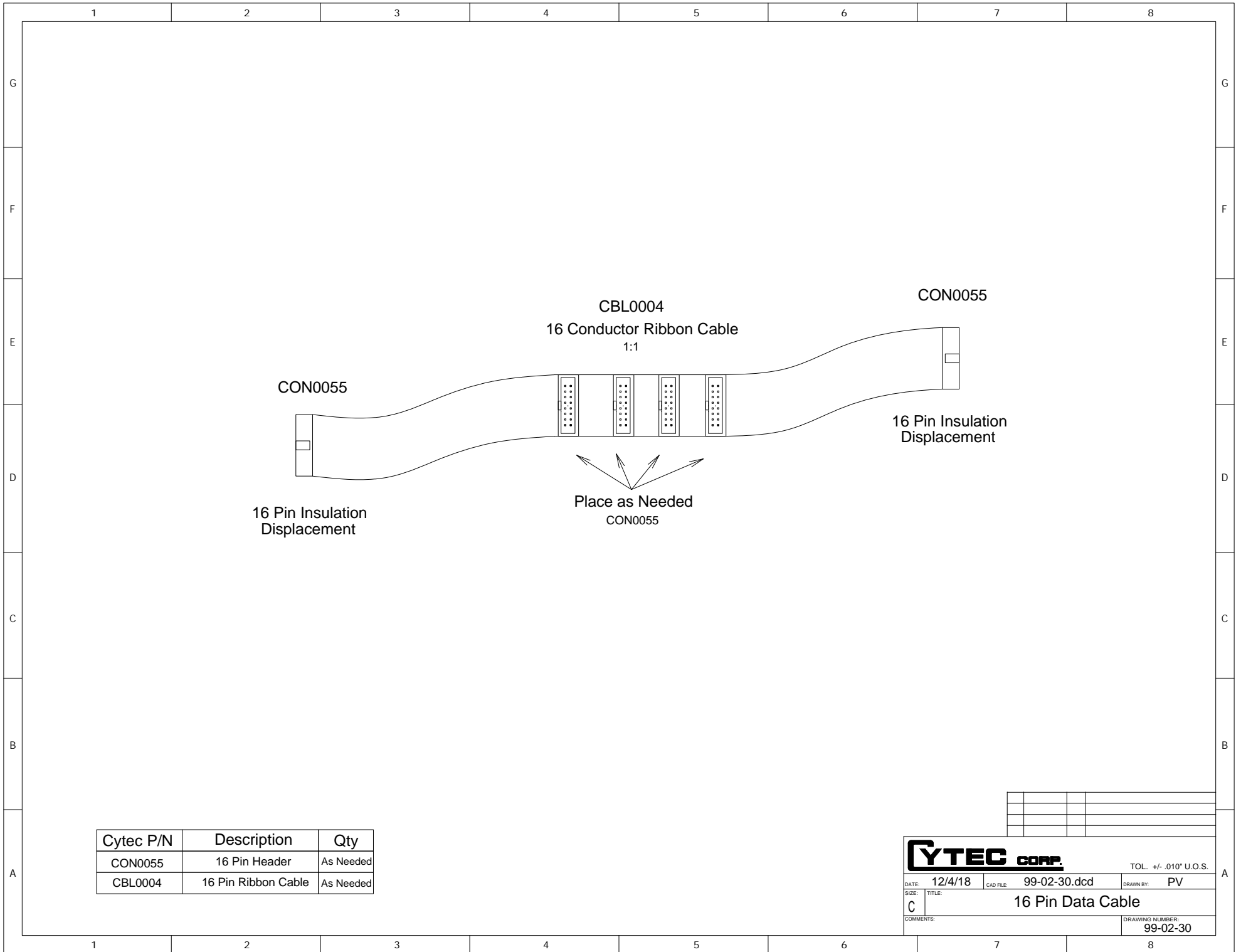

Cytec P/N	Description	Qty
CON0055	16 Pin Header	As Needed
CBL0004	16 Pin Ribbon Cable	As Needed

CYTEC CORP.		TOL. +/- .010" U.O.S.	
SIZE: C	TITLE: 16 Pin Data Cable	DRAWN BY: PV	
COMMENTS:		DRAWING NUMBER: 99-02-30	

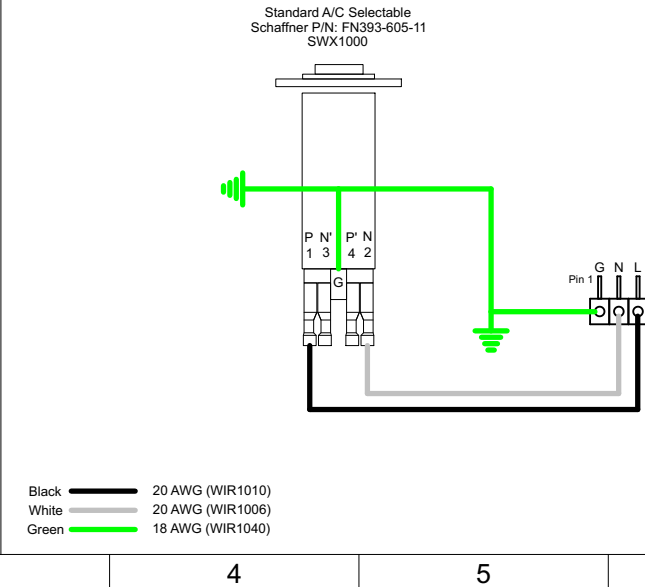
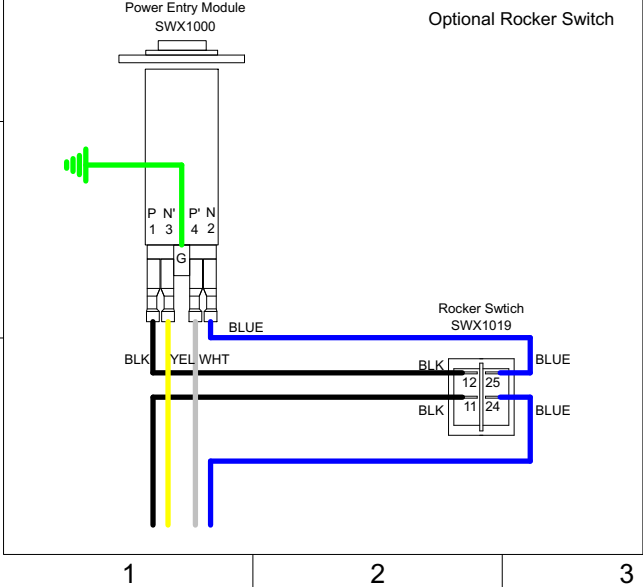
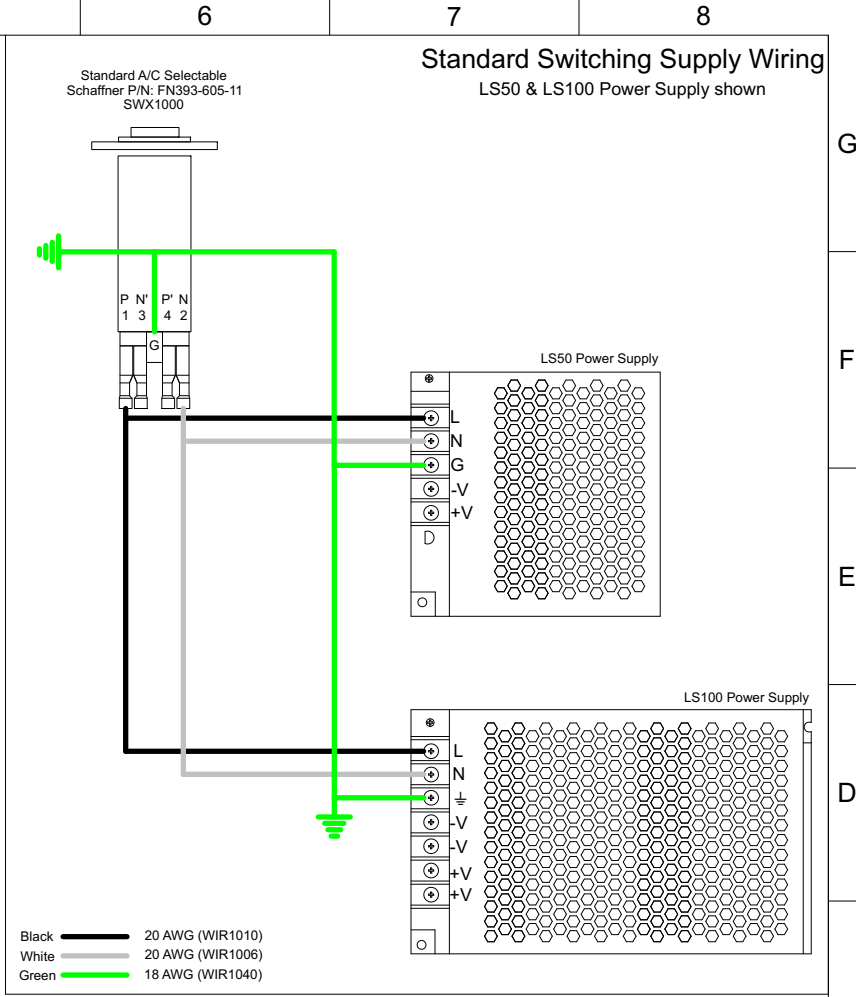
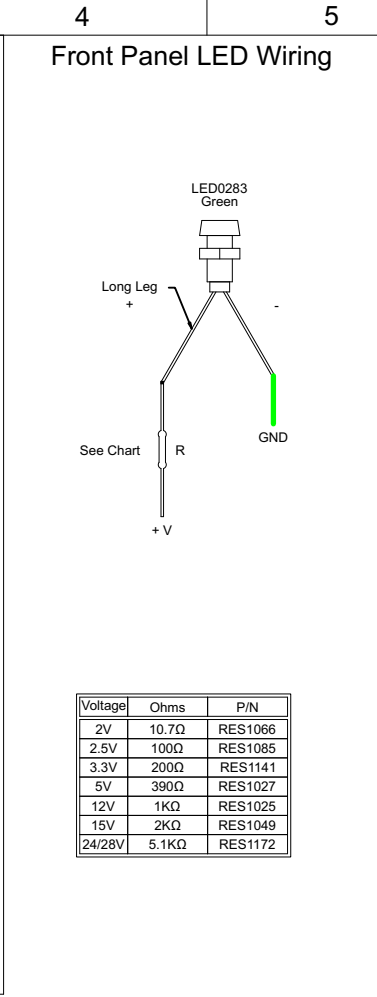
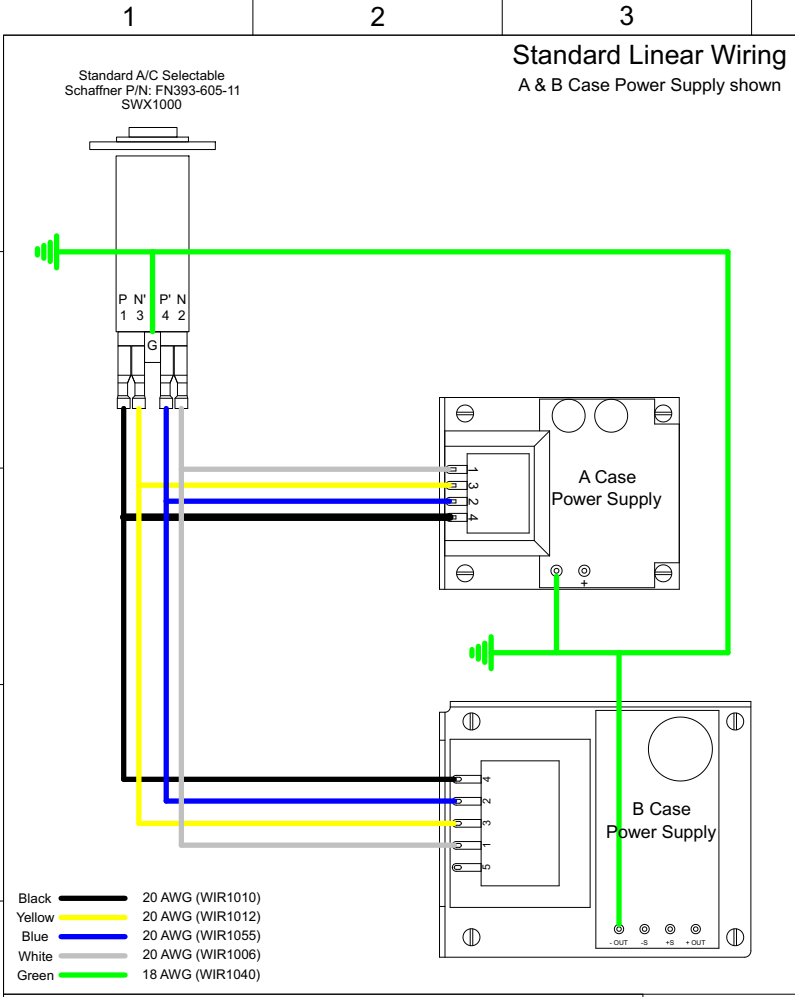

A	1/27/20	PV	Tied Gnd on Dual Supplies
-	5/2/18	PV	Drawing Start

YTEC CORP. TOL. +/- 0.01" U.O.S.

Date: 5/2/18 CAD File: 99-190-30 Rev A.dxf Drawn By: PV

Size: Title: **A** Standard Power Supply Wiring

Comments: Drawing Number: 99-190-30 1/2

Linear Supply Dual Supplies Shown

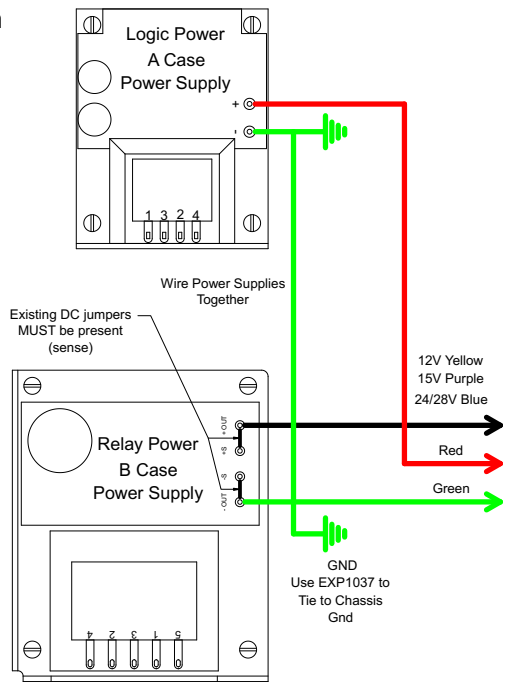

- Green — 20 AWG (WIR1009)
- Red — 20 AWG (WIR1011)
- Yellow — 20 AWG (WIR1012)
- Purple — 20 AWG (WIR1003)
- Gray — 20 AWG (WIR1039)
- Blue — 20 AWG (WIR1055)

Switching Supplies

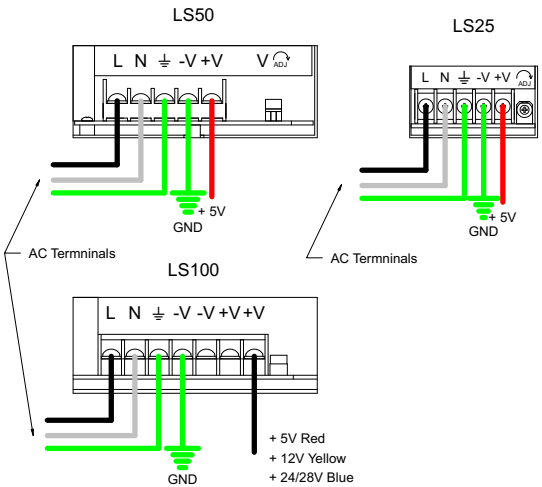

- Green — 20 AWG (WIR1009)
- Red — 20 AWG (WIR1011)
- Yellow — 20 AWG (WIR1012)
- Purple — 20 AWG (WIR1003)
- Gray — 20 AWG (WIR1039)
- Blue — 20 AWG (WIR1055)

+ 12V Supply & 5V Regulator

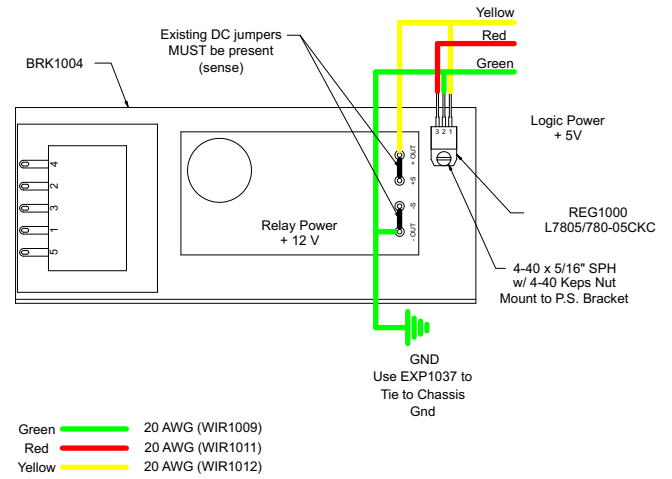

11-14-10
IF-11 Control Module
CON1131
J3



11-11-10
RD-9 Relay Driver Module
CON1131
J5

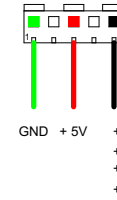

11-17-10
RD-8/16 Relay Driver Module
CON1131
J3

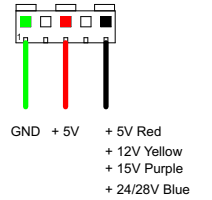

12-01-10
CP Motherboard
CON1131

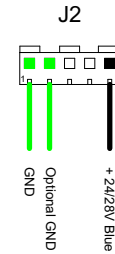
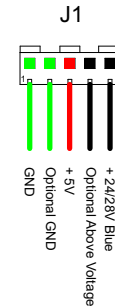

- Green — 20 AWG (WIR1009)
- Red — 20 AWG (WIR1011)
- Yellow — 20 AWG (WIR1012)
- Purple — 20 AWG (WIR1003)
- Gray — 20 AWG (WIR1039)
- Blue — 20 AWG (WIR1055)

A	1/27/20	PV	Tied Gnd On Dual Supplies
-	5/2/18	PV	Drawing Start

YTEC CORP. TOL. +/- 0.01" U.O.S.

Date: 5/2/18 CAD File: 99-190-30 Rev A.dxf Drawn By: PV

Size: Title: **A Standard Power Supply Wiring**

Comments: Drawing Number: 99-190-30 2/2

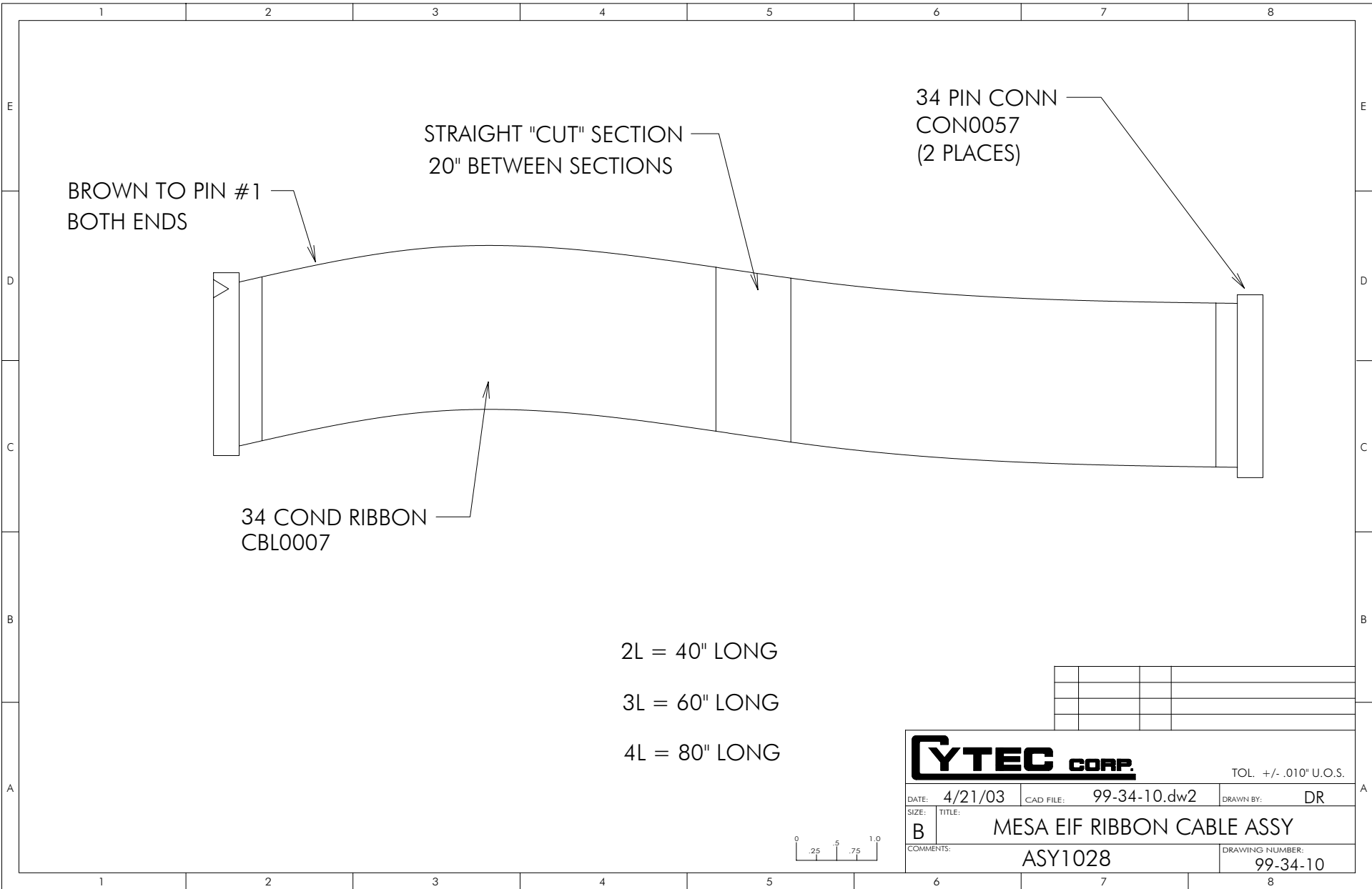

BROWN TO PIN #1
BOTH ENDS

STRAIGHT "CUT" SECTION
20" BETWEEN SECTIONS

34 PIN CONN
CON0057
(2 PLACES)

34 COND RIBBON
CBL0007

- 2L = 40" LONG
- 3L = 60" LONG
- 4L = 80" LONG

YTEC CORP.

TOL. +/- .010" U.O.S.

DATE:	4/21/03	CAD FILE:	99-34-10.dw2	DRAWN BY:	DR
SIZE:	B	TITLE:	MESA EIF RIBBON CABLE ASSY		
COMMENTS:	ASY1028			DRAWING NUMBER: 99-34-10	

