

DRIVE JUMPER KEY

8x1 & 4x1 Using Drives 0-3

4x1 Using Drives 4-7

JUMPER PINS	DRIVE	JUMPER PINS	DRIVE
1,2	0	13,14	4
3,4	1	11,12	5
5,6	2	7,8	6
15,16	3	9,10	7

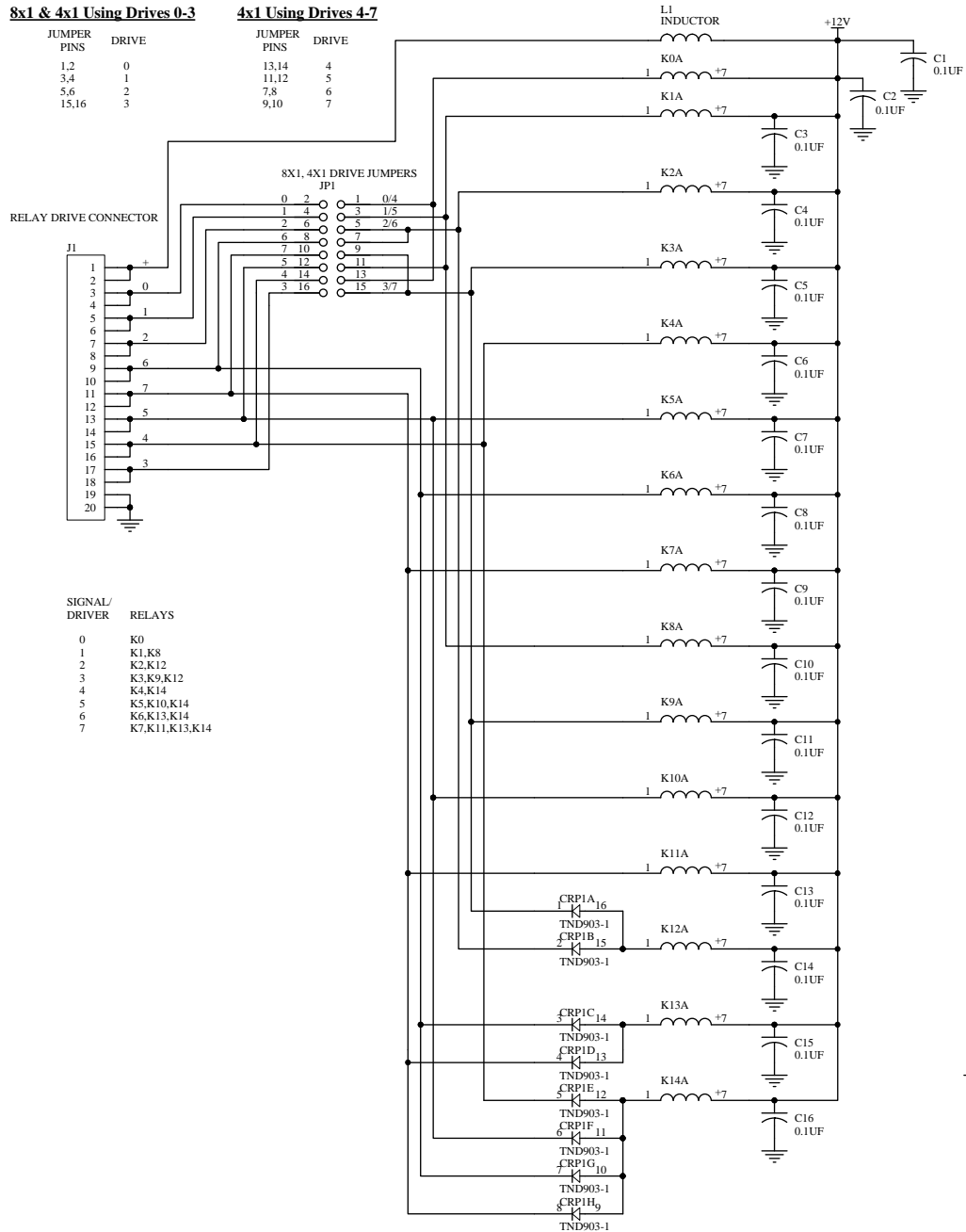

SIGNAL/DRIVER	RELAYS
0	K0
1	K1, K8
2	K2, K12
3	K3, K9, K12
4	K4, K14
5	K5, K10, K14
6	K6, K13, K14
7	K7, K11, K13, K14

RELAY GROUNDS

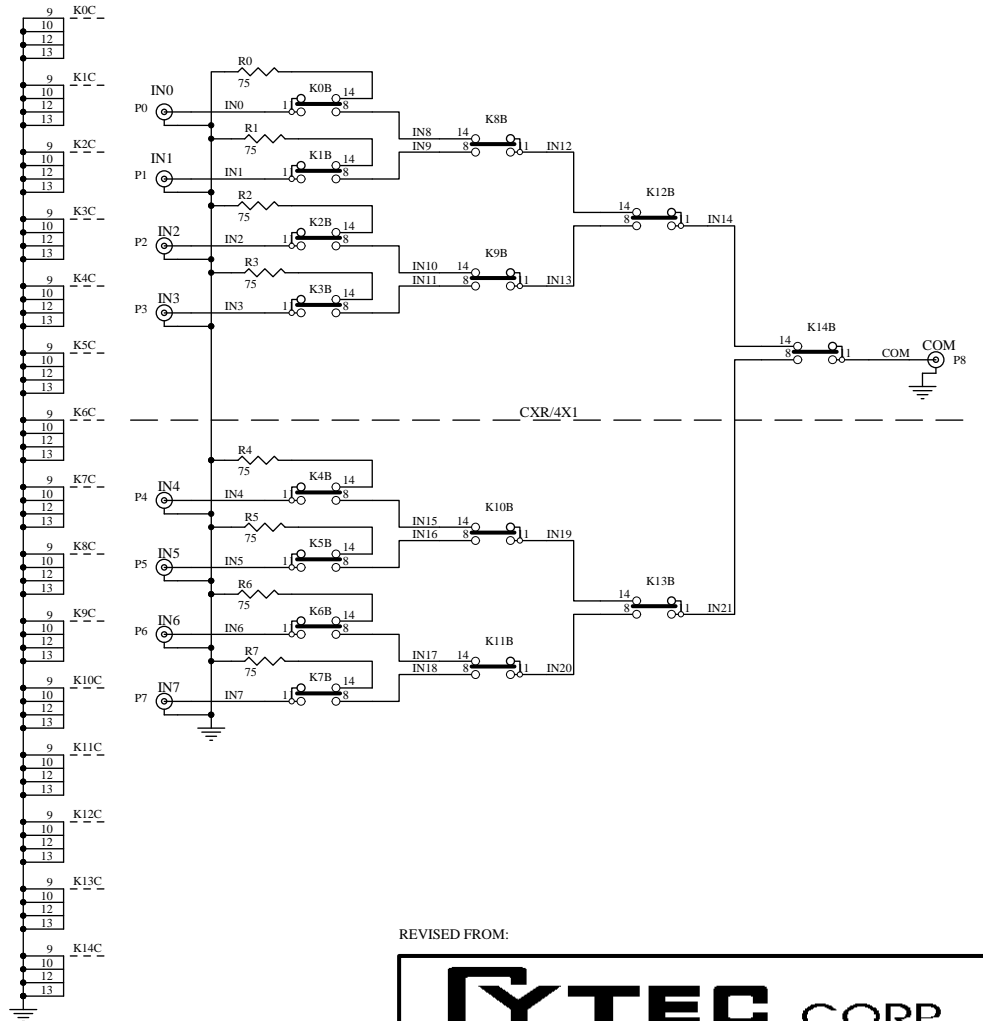

REVISED FROM:

YTEC CORP.		
APPROVED BY	DRAWING NUMBER	DRAWN BY: RHB
DATE: 10/1/2013	30-19-50	REVISION:
SIZE: A3	TITLE: CXR/8X1-GT-75	
30-19-50	SHEET 1 OF 1	