

## CX SERIES COAXIAL AND RF SWITCHING MATRIX

The CX Series of Switching Matrices are available in a variety of single wire coax configurations designed to operate in the range from DC to 700 MHz with many options to minimize price while meeting the desired specifications.

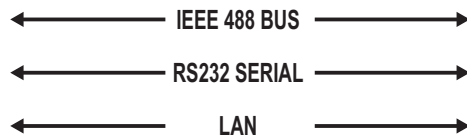

CXG/8x8 50 ohm Mainframe

## CX MAINFRAMES AND EXPANSION CHASSIS

### CXB MAINFRAMES -- DC to 50 MHz

Modular Systems with BNC connectors available in incremental nonblocking configurations from 1x8 to 16x8, or from 2x4 to 32x4. 19" rackmount chassis, 3.5" high. See page CX-2 of bulletin for complete specifications.

### CXE MAINFRAMES -- DC to 50 MHz

Modular Systems with BNC connectors available in incremental nonblocking configurations from 2x8 to 32x8. 19" rackmount chassis, 3.5" high. See page CX-2 of bulletin for complete specifications.

### CXG MAINFRAMES -- DC to 700 MHz

Available as 4x8 or 8x8 nonblocking matrices in 50 or 75 ohm characteristic impedance. Available with BNC, SMA or user specified connectors. 19" rackmount chassis, 7" high. See page CX-3 of bulletin for complete specifications.

### CXF MAINFRAMES -- 10 MHz to 500 MHz

Available as 4x8 or 8x8 nonblocking, full fan-out matrices with 50 ohm characteristic impedance. Available with BNC, or SMA connectors. 19" rackmount chassis, 7" high. See page CX-3 of bulletin for complete specifications.

### CXL MAINFRAMES -- DC to 700 MHz

Affordable 8x8 blocking matrix with 50 ohm characteristic impedance. Available with BNC, SMA or user specified connectors. 19" rackmount chassis, 3.5" high. No LED indicators. See page CX-4 of bulletin for complete specs.

### CONTROL OPTIONS

#### IF-5 IEEE488/RS232

This Module has both the IEEE488 (Talk /Listen) and the RS232 features detailed in Applications Bulletin AP-5.

#### IF-6 LAN INTERFACE

This Module uses TCP/IP to allow control from a Local Area Network as described in Applications Bulletin AP-5.

### MANUAL CONTROL OPTIONS

#### M/128-TW OR M/256-TW THUMBWHEEL CONTROLS

This manual control uses a thumbwheel selector and strobe button to select switchpoints.

#### MC/2 KEYPAD MANUAL CONTROL W/ LCD DISPLAY

This manual control has a keypad and LCD display of last command.

#### VMC VIRTUAL MANUAL CONTROL SOFTWARE

The VMC Software allows the remote operator to view the Status of the Matrix and to Control Switch Selection using a full Graphical User Interface. All Windows based versions are available. Free with any system purchase.

# CXB SERIES MODULAR SWITCH MATRIX

The CXB Series of Modular Coaxial Switch Matrices provide incremental matrix sizes from 2x4 or 1x8 up to 32x4 or 16x8. 50 ohm signals from DC to 50 MHz can be switched, with isolation of -50 dB at 50 MHz. Up to 16 CXB Switch modules and CL8 Display modules are plugged into the coaxial motherboard to supply the required matrix configurations as shown in Figs. 1 and 2. The CL8 Display modules provide visual indication of switch status to aid in troubleshooting test routines and debugging programming. The modules are available with Type S dry reed relays or Type M mercury wetted reed relays for up to 50 watt switching.

## CXB CHASSIS

CXB/16x8 and CXB/32x4 Mainframes and Expansion Chassis are built for either Nx8 or Nx4 Matrix configurations, where the number of installed switch modules determines the number of connections in the N direction. All systems are completely bidirectional, so either side of the matrix may be considered inputs or outputs. Expansion chassis are used with a MESA Control chassis for cost effective configuration of matrix sizes which exceed the limits of a single chassis. See the **MESA Bulletin** for details on building larger systems.

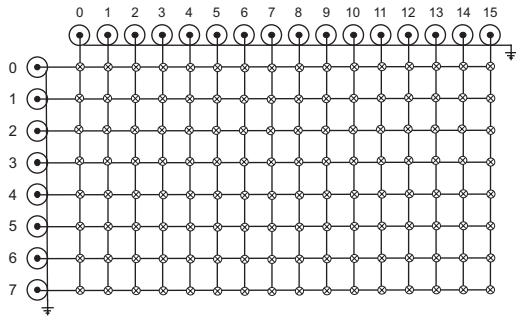

Fig. 1

CXB/16x8 Matrix Chassis

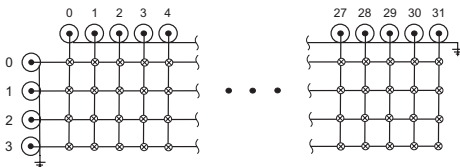

Fig. 2

CXB/32x4 Matrix Chassis



CXB/16x8 or 32x4 Matrix

## CXB SWITCH MODULES

### CXB/1x8-1S or -1M SWITCH MODULE

These modules are used with CXB/16x8 Chassis to provide Nx8 matrices. Each module supplies one connection in the N direction as shown in Fig. 3, and a total of 16 modules will form a 16x8 matrix. Each switch module requires one CL8 Display/Driver module.

Fig. 3

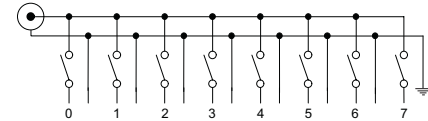

### CXB/2x4-1S or -1M SWITCH MODULE

These modules are used with CXB/32x4 Chassis to provide Nx4 matrices. Each module supplies two connections in the N direction as shown in Fig. 4, and a total of 16 modules will form a 32x4 matrix. Each switch module requires one CL8 Display/Driver module.

Fig. 4

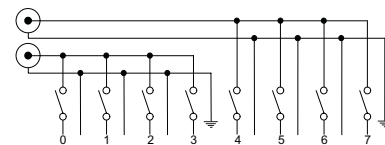

# CXE/32x8 MODULAR MATRIX

The CXE/32x8 Matrix uses CXE/2x8 Switch Modules to form modular systems in the same manner as the CXB systems shown above. Each switch module has 16 single pole coaxial relays configured as a 2x8 matrix with additional isolation relays as shown in Fig. 5. Installing up to 16 modules in the matrix chassis allows the formation of matrices up to 32x8 as shown in Fig. 6. Each CXE Switch Module requires one CLE/16 Display Module for control and LED display of selected relays. All remote control options are available. A fully populated CXE/32x8 has a bandpass of DC to 50 MHz (-3dB) with Isolation of -50 dB at 50 MHz. Inputs and outputs are fully bidirectional and use BNC connectors.

Fig. 5

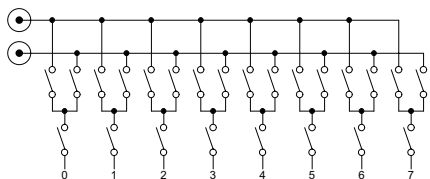

CXE/2x8 Switch Module

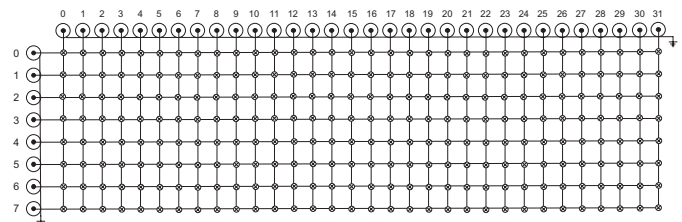

Fig. 6

CXE/32x8 Matrix

# CXG SERIES DC to 700 MHz COAXIAL MATRIX

CYTEC's CXG Series of coaxial tree switch matrices are available as 4x8 or 8x8 nonblocking configurations in 50 or 75 ohm characteristic impedance. The tree switch topology shown in Fig. 7, provides excellent attenuation and crosstalk specifications from DC to 700 MHz. The use of electro-mechanical relays make these systems completely bidirectional and capable of hot switching signals up to 24 watts. 50 ohm systems are available with BNC, SMA or other user specified connectors. 75 ohm systems are available with BNC or SMB connectors. Any of CYTEC's standard control modules may be specified as well as the MC/2 Keypad manual control.

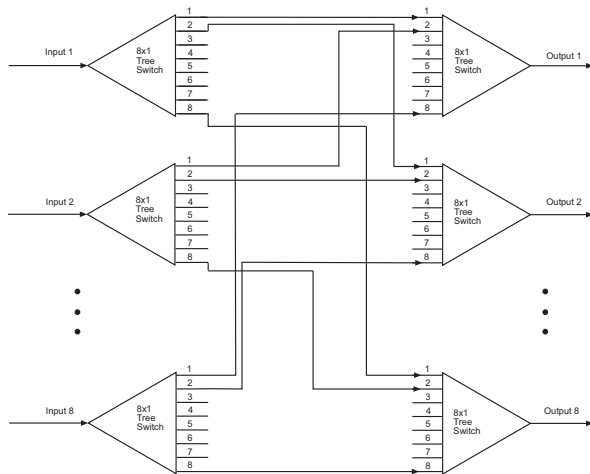
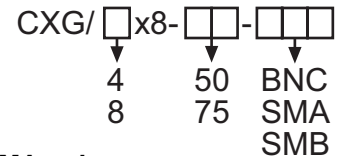

Fig. 7

## SPECIFICATIONS

Bandpass(50 ohm)	DC to 700 MHz (-3 dB)
Bandpass(75 ohm)	DC to 500 MHz (-3 dB)
Isolation	-60 dB to 700 MHz
VSWR	<1.4
Impedance	50 or 75 ohm
Switched Power	24 watts max
Switch speed	10 ms
Signal Connections	See below
19" rackmount Size	7" high, 15.6" deep
Weight	Approximately 25 lbs

### How to order:



50 ohm systems BNC or SMA only  
75 ohm systems BNC or SMB only

# CXF SERIES FULL FANOUT 5-500MHz COAXIAL MATRIX

This system is a nonblocking (any input to any output), full fan out (any input to any or all outputs), 50 ohm coaxial switch matrix available in 4x8 or 8x8 configurations as shown in Fig. 8. Larger configurations can be supplied using multiple Expansion Chassis and a MESA Control Chassis. Systems are built with BNC or SMA as standard connectors. Other connector styles available on request. The matrix has LED visual display of latched switch paths and is available with any of the standard control modules.

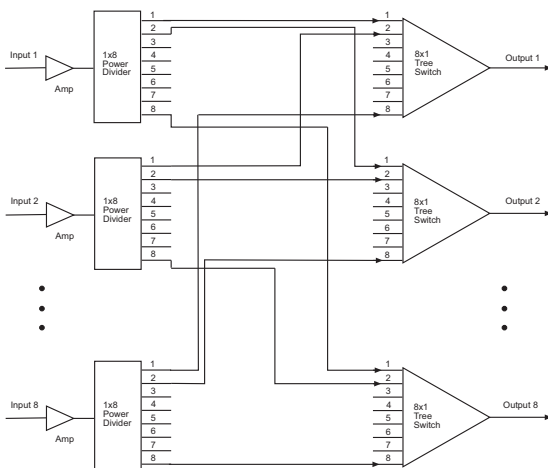
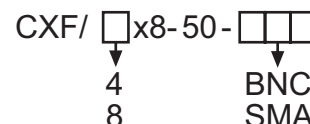

Fig. 8

## SPECIFICATIONS

Bandpass	5 MHz to 500 MHz (+/- 2 dB)
Isolation	-65 dB to 500 MHz
VSWR	<1.6:1 to 500 MHz
Impedance	50 ohm
Switched Power	+2.0 dBm
Switch Speed	10 ms
Signal Connections	SMA or BNC on rear panel
19" Rackmount	7" high, 15.6" deep
Weight	Approximately 25 lbs

### How to order:



# CXL SERIES 8x8 BLOCKING MATRIX

The CXL/8x8 blocking matrix is a compact and affordable, DC to 700 MHz coaxial 8x8, bidirectional matrix as shown in Fig. 9. The system will allow any input to be connected to any output but requires that the entire switch is reconfigured in order to establish a new path. This may cause a momentary disconnect in previously set paths when a new connection is desired.

The CXL/8x8 is an extremely cost effective solution for tests which are not reconfigured during the test run, or can tolerate momentary loss of signal during reconfiguration.



## SPECIFICATIONS

<b>Bandpass</b>	DC to 700 MHz (-3 dB)
<b>Isolation</b>	-60 dB to 700 MHz
<b>VSWR</b>	< 1.4 to 700 MHz
<b>Impedance</b>	50 ohms
<b>Max Switched Power</b>	24 Watts
<b>Max Switched Current</b>	1 Amp
<b>Relay type</b>	High frequency Armature
<b>Connectors</b>	BNC or SMA
<b>Configuration set-up time</b>	0.1 seconds
<b>Chassis Dimensions</b>	19" rackmount, 3.5" high, 15.6" deep
<b>Weight</b>	15 lbs
<b>Power Consumption</b>	< 50 Watts with all paths closed

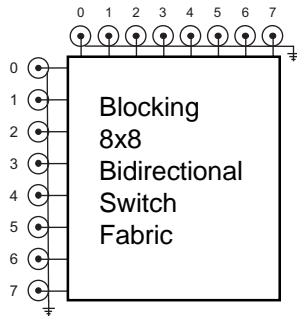

Fig. 9

## RELAY SPECIFICATIONS

Three types of relays are used in CX Series Matrices:

**Type S Reed Relay** - This is a single pole Form A dry reed switch for low power applications.

**Type M Reed Relay** - This is a single pole Form A mercury wetted reed switch for higher power applications.

**Type A Armature Relay** - This is a single pole Form C armature relay for RF applications.

The **CXB Series** is available with either **Type S** or **Type M**.

The **CXE Series** uses **Type S** only.

The **CXG, CXF and CXL Series** all use **Type A** relays.

Reed relays are guaranteed for 100 million operations, and Armature relays are guaranteed for 1,000,000 operations if used within the following ratings:

	Type S	Type M	Type A
Contact Rating	10VA	50VA	24 Watts
Switch Voltage	200V	500V	24V
Switch Current	0.5A	2.0A	1A
Breakdown Voltage	400V	1000V	200V
Operating Time	1ms	2ms	10ms

## GENERAL SPECIFICATIONS

**WEIGHT** - 30 lbs. max for full systems.

**POWER** - 100-130 VAC or 200-240 VAC 50-60 Hz

**POWER CONSUMPTION** - < 100 watts.

**ENVIRONMENT** - Operating at 0°C to 50°C.

Storage at -25°C to 65°C.

**AVAILABILITY** - Most systems available 30 days ARO.

## WARRANTY

CYTEC Corp. warrants that all products are free from defects in Material and Workmanship for a period of 5 years and that all switches are guaranteed for their Rated Operations. A 10 year warranty/service agreement is available with the purchase of specified spare parts.

## RAM OPTION

This option is available with the IF-5 Control Module and allows up to 100 Switch selections to be stored in memory. It also allows automatic reset to specific configurations on Power Up.

## SOFTWARE

Drivers and Sample Programs are available for the most common programming languages. These check the entire system by cycling through all switches, sequentially latching and unlatching each switch while checking Status.

**CONTACT 1-800-346-3117 OR WWW.CYTEC-ATE.COM FOR TECHNICAL ASSISTANCE**